



Dark Matter: Particle Properties II

Tim M.P. Tait
University of California, Irvine



Pre-SUSY 2015
August 20, 2015

Outline for Lecture II

- KK parity: UED Dark Matter
 - 5d UED Dark Matter
 - The 6d Chiral Square
- T-parity
- Super-WIMPs
- “Designer” Dark Matter
- Complementarity of Searches

Universal Extra Dimensions

- Our next entry in the catalogue has “Universal Extra Dimensions”
- The basic premise is that in addition to the large dimensions we are familiar with, there is one or more small, curled up dimensions.
 - R smaller than $(\text{a few hundred GeV})^{-1}$.
- All of the quantum fields are functions of the four large (ordinary) coordinates x as well as the extra (compact) coordinates y .
- We’ll take a look at both 5d and 6d versions.

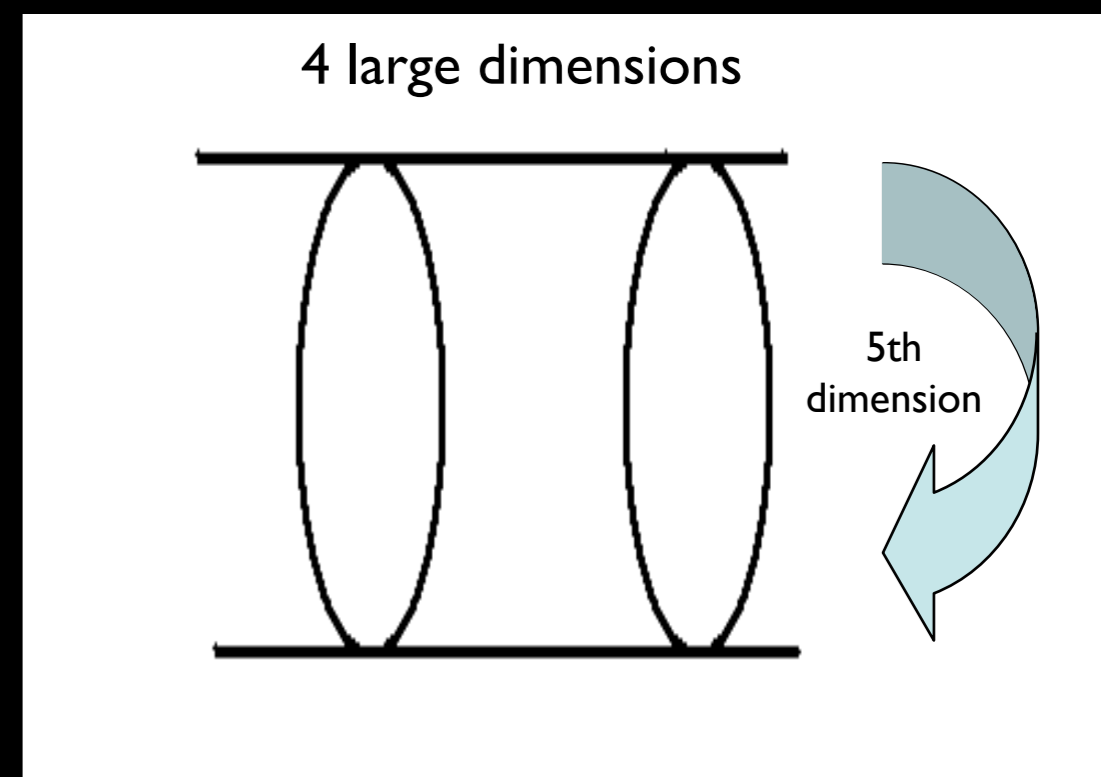

Field Theory in 5 Dimensions

- To begin with, imagine our extra dimension is a circle (S¹), requiring wave functions to be periodic as one traverses the extra dimension.
 - Mathematically, this is the particle-in-a-box problem familiar from basic QM.
 - The 5th component of Momentum (p₅) is quantized in units of $1/R$.
- States with p₅ different from zero appear massive to an observer who does not realize the extra dimension is there.

$$p_0^2 - \vec{p}^2 - p_5^2 = 0 \quad \longrightarrow \quad p_0^2 - \vec{p}^2 = p_5^2 = m_{\text{eff}}^2$$

- We (and all low energy physics) are composed of the lowest (n=0) modes.
- Each SM field comes with a tower of massive states with the same charge and spin as the zero mode, but with masses given by n/R .

Kaluza-Klein Particles

- The translational invariance along the extra dimensional direction implies conservation of p_5 , or in other words, of KK mode number.
- Clearly, all fields must “live” universally in the extra dimension for there to be translational invariance -- this is not a brane world.
- The conserved KK number implies that the Lightest Kaluza-Klein Particle is stable.
 - Usually the $n=1$ KK “Photon”.
- From the extra dimensional point of view: a photon is massless and cannot be dark matter, but if one is circulating around in a hidden dimension, to an outside observer, it appears to be a massive particle at rest.

Sample Interactions

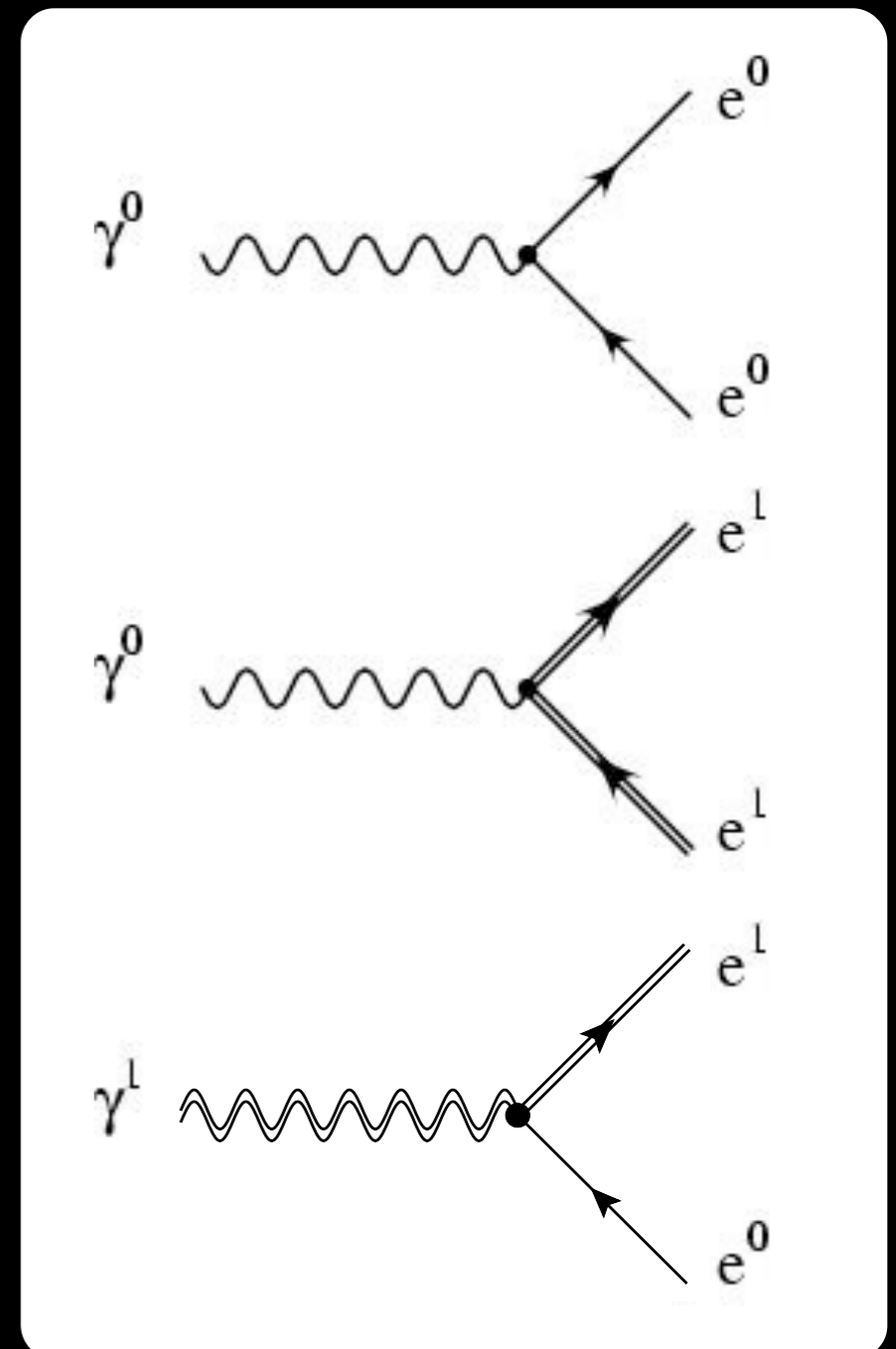

Why Universal Extra Dimensions?

- String Theory:
 - String theories require supersymmetry and extra dimensions to be consistent. So extra dimensions are (from a low energy point of view), the “other half” of stringy phenomenology.
- Number of generations:
 - Cancellation of anomalies in six dimensions requires the number of families to be a multiple of three!
- Dark Matter!

Dobrescu, Poppitz
PRL87, 031801 (2001)

Orbifold

- Our circular extra dimension is not quite realistic. It contains unwanted zero-mode degrees of freedom:
 - 5d vector bosons contain a 4d vector V_μ and scalar V_5 .
 - Massless 5d spinors have 4 components, leading to mirror fermions at low energies.
- Orbifold boundary conditions project out the unwanted degrees of freedom:
 - Instead of a circular extra dimension, we fold the circle, identifying y with $-y$.
 - This results in a line segment, with the points 0 and πR at the end-points.
 - Boundary conditions forbid the unwanted zero modes.

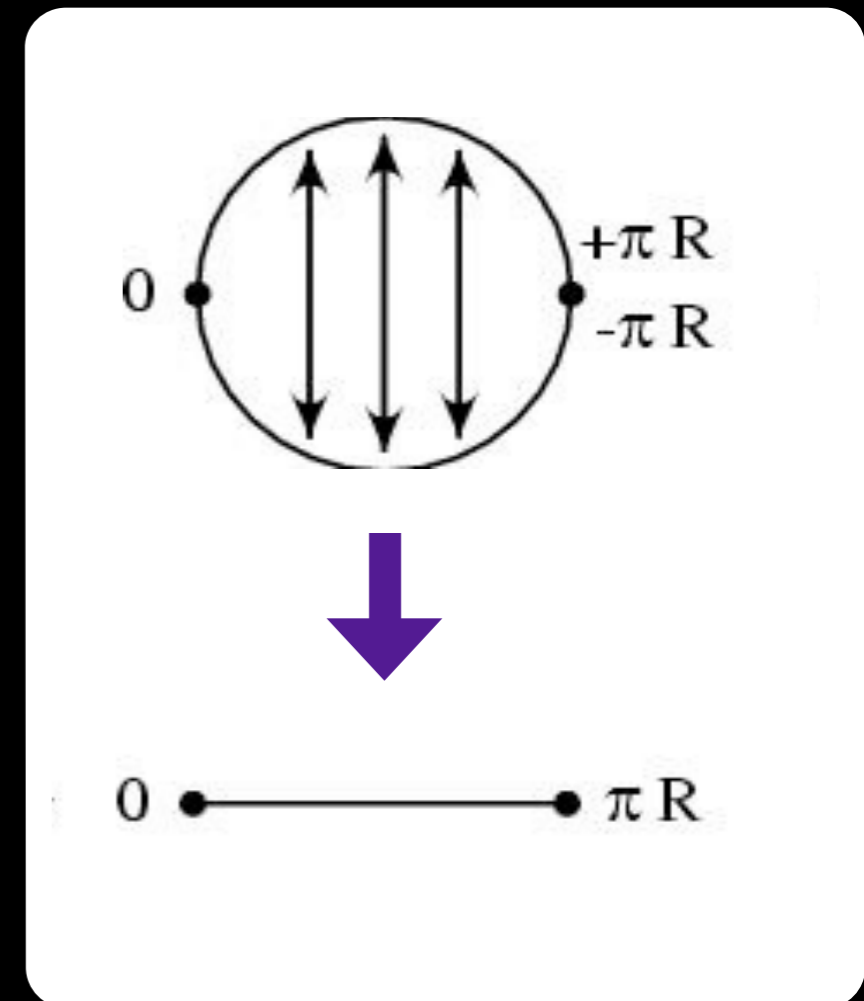

$$V_\mu(-y) = V_\mu(y)$$

$$V_5(-y) = -V_5(y)$$

$$\Psi(-y) = \gamma_5 \Psi(y)$$

Orbifolds are Opaque

- Even theories without localized fields have terms living on their boundaries.
- The orbifold, identifying (y and $-y$), implies the theory can't tell one direction from another.
- Loops of bulk fields generate p5 non-conserving terms.
- In position space, these are equal size terms living on the boundaries.
- The loops are log-divergent, indicating that they are not calculable -- they are parameters of the effective theory.

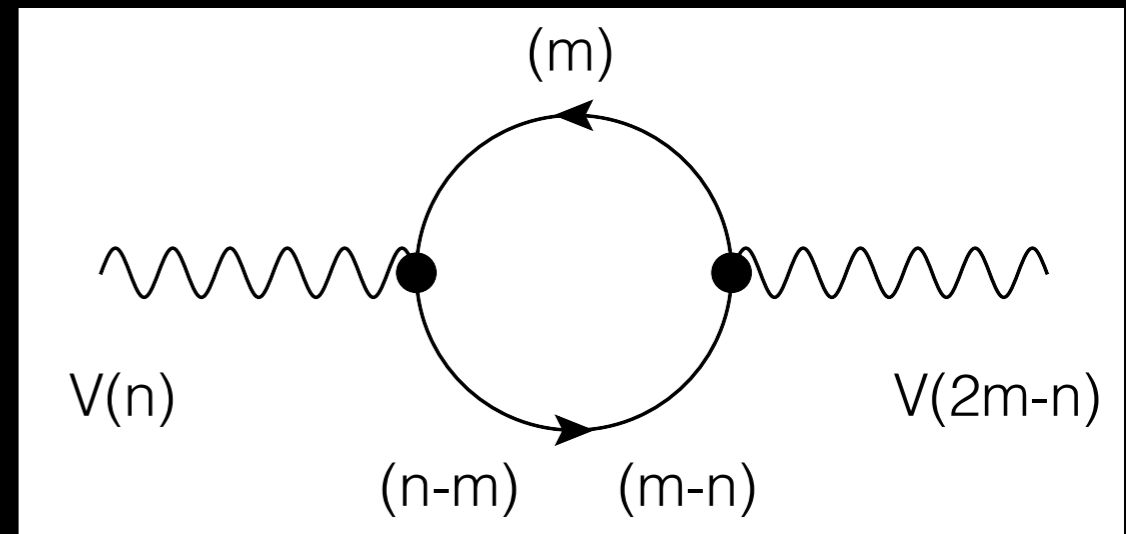

Georgi, Grant, Hailu, PLB506, 207 (2001)

$$-\frac{r_c}{4} \left[\delta(y) + \delta(y-L) \right] F_{\mu\nu} F^{\mu\nu}$$

$$r_c : \frac{\alpha_5}{4\pi} \log \left[\frac{\Lambda}{\mu} \right]$$

Opaque Orbifolds

The boundary terms modify the KK expansion, reshuffling modes in the expansion.

This has the effect of changing the KK mass spectrum.

It breaks conservation of KK number down to a KK parity under which odd KK number modes are odd.

Much like R-parity, the lightest odd mode is stable, and odd modes are produced in pairs.

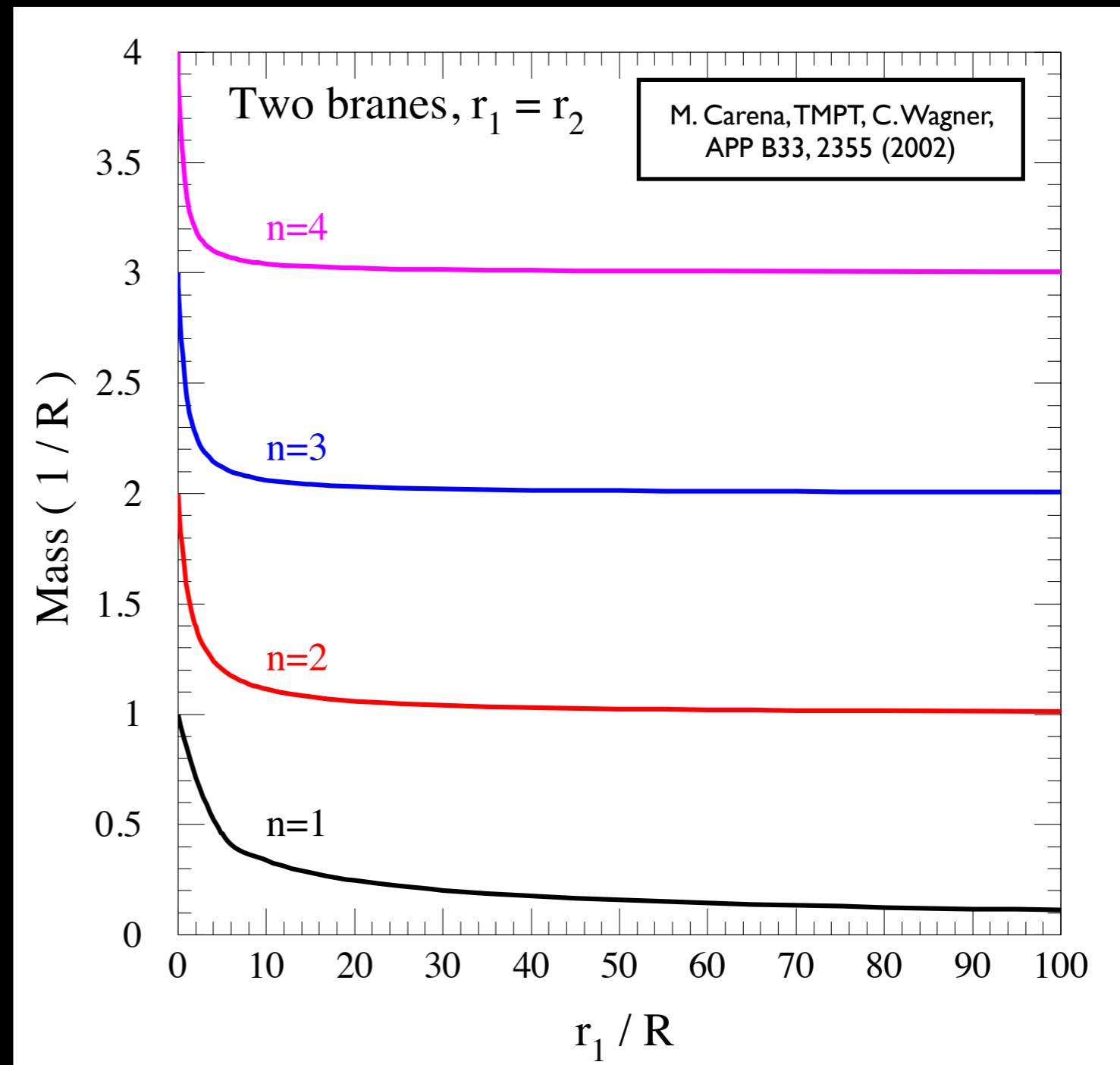

KK Mode Spectrum

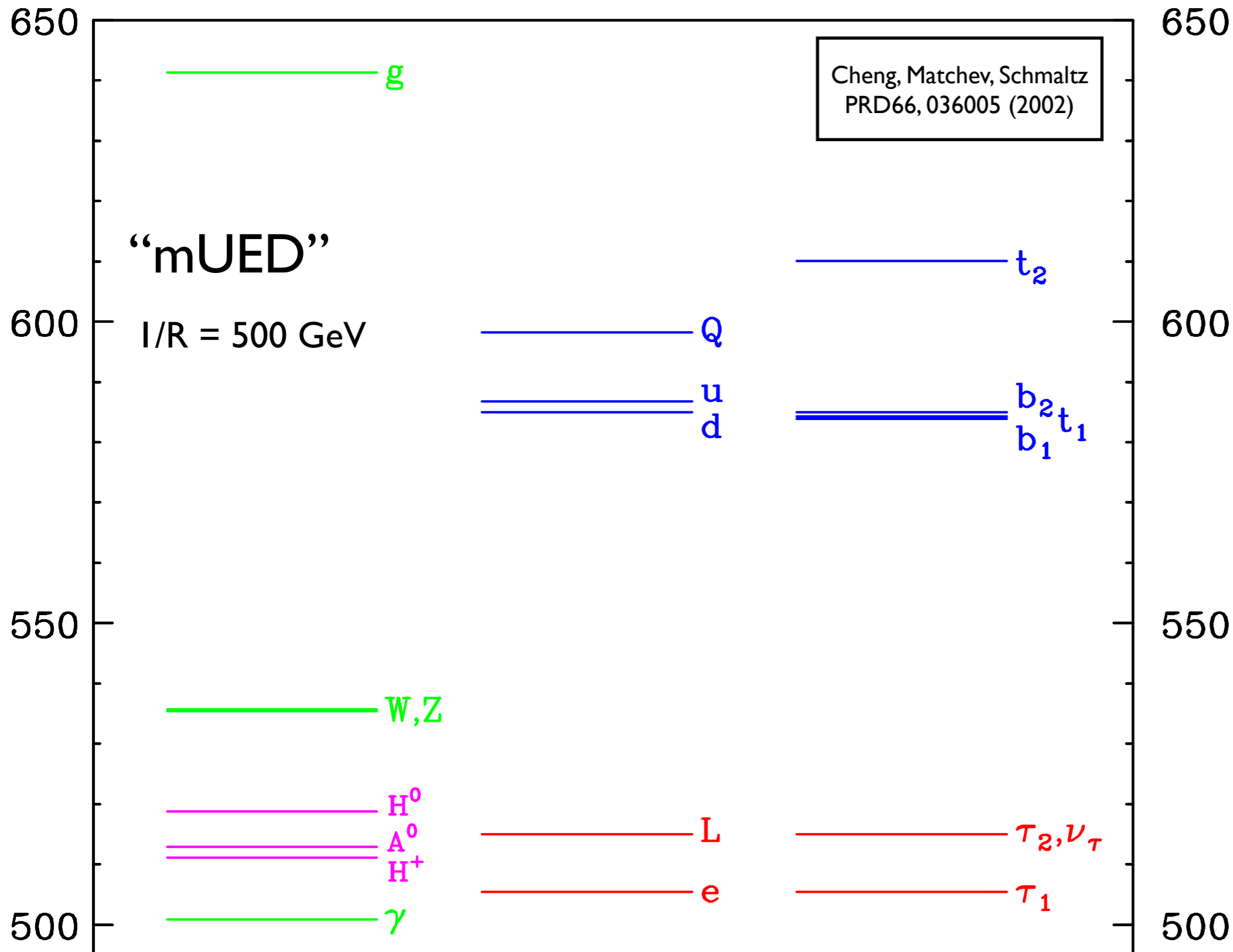

SU(3)-
Charged

SU(2)-
Charged

U(1)-Charged

KK Mode Spectrum

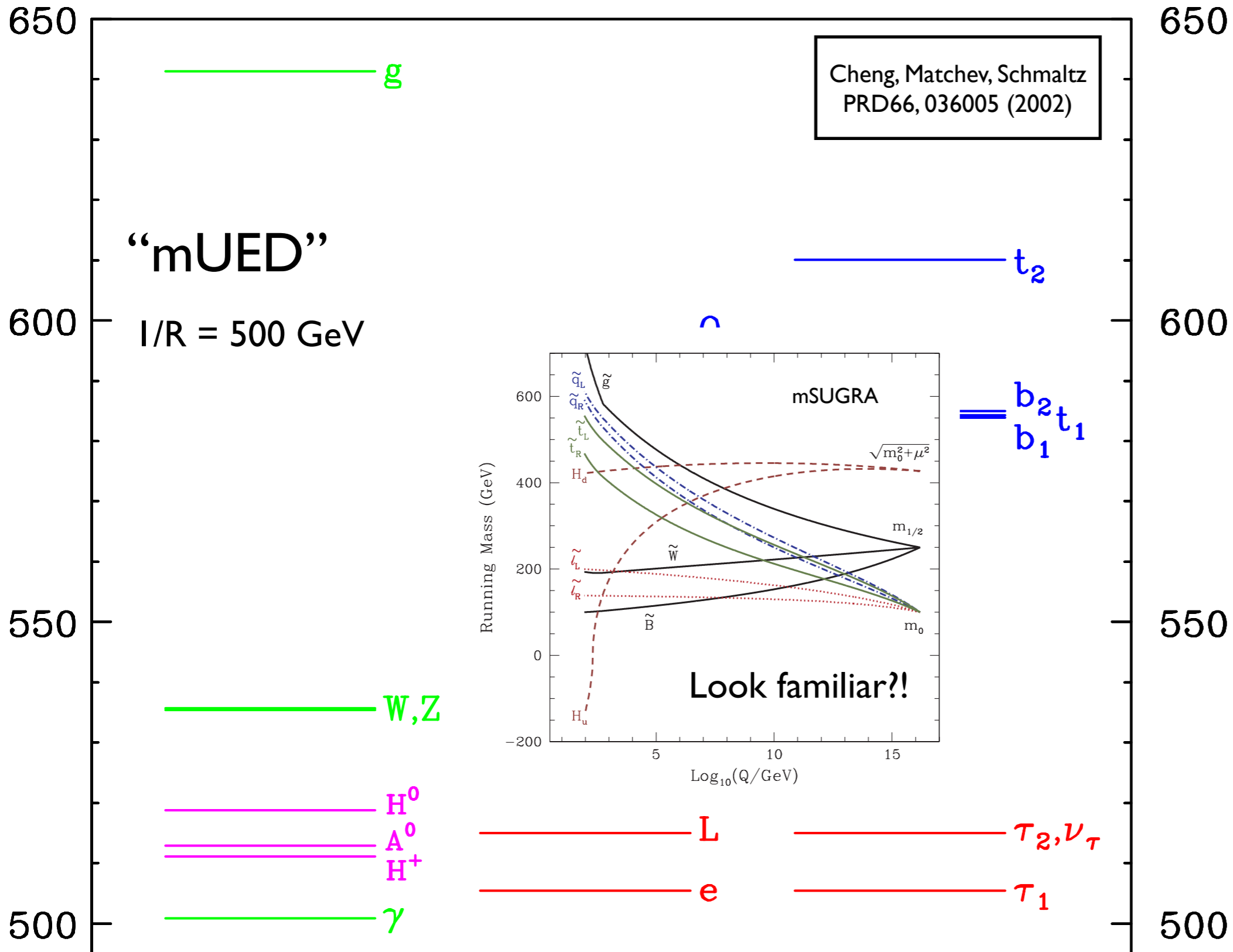

} SU(3)-
Charged

} SU(2)-
Charged

} U(1)-Charged

Identity of the LKP

- Boundary terms play a role similar to SUSY soft masses, determining masses and couplings for the entire KK tower.
- If we imagine the terms are zero at the cut-off, they will be induced at loop size.
- Since $\alpha_1 \ll \alpha_2 \ll \alpha_3$, we imagine the smallest corrections will be to the U(1) gauge boson.
- Since $\delta M \sim 1/R \gg v$, the LKP is (almost) purely a KK mode of the U(1) gauge boson, $B_\mu^{(1)}$.
- Following this line of reasoning, the NLKP is the right-handed electron, $e_R^{(1)}$.

$B^{(1)} - W_3^{(1)}$ Mass² matrix

$$\begin{pmatrix} \frac{1}{R^2} + \frac{1}{4} g_1^2 v^2 + \delta M_1^2 & \frac{1}{4} g_1 g_2 v^2 \\ \frac{1}{4} g_1 g_2 v^2 & \frac{1}{R^2} + \frac{1}{4} g_2^2 v^2 + \delta M_2^2 \end{pmatrix}$$

$$\delta M^2 : \frac{1}{R^2} \frac{\alpha}{4\pi} \log(\Lambda R)$$

LKP Annihilations

- For a pure $B^{(1)}$ LKP, we know couplings are controlled by the hypercharges.
- There are annihilations into SM fermions and Higgs bosons.
 - 59% Charged Leptons
 - 35% Hadrons
 - 4% Neutrinos
 - 2% Higgs/Goldstone bosons
- As bosons, there are no restrictions from Fermi statistics: cross sections are generally larger than for SUSY bino WIMPs.

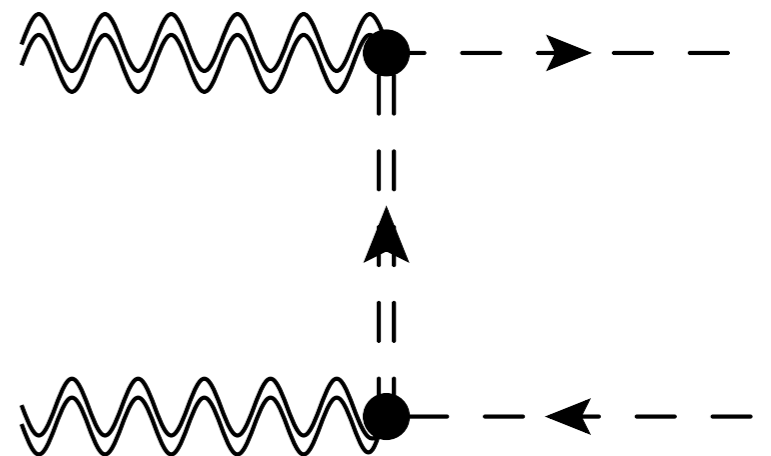
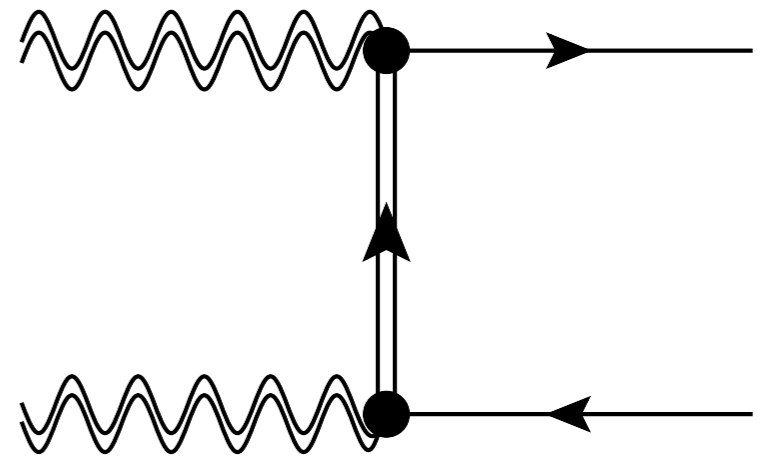

LKP Relic Density

G. Servant, TMPT, NPB650, 351 (2003)

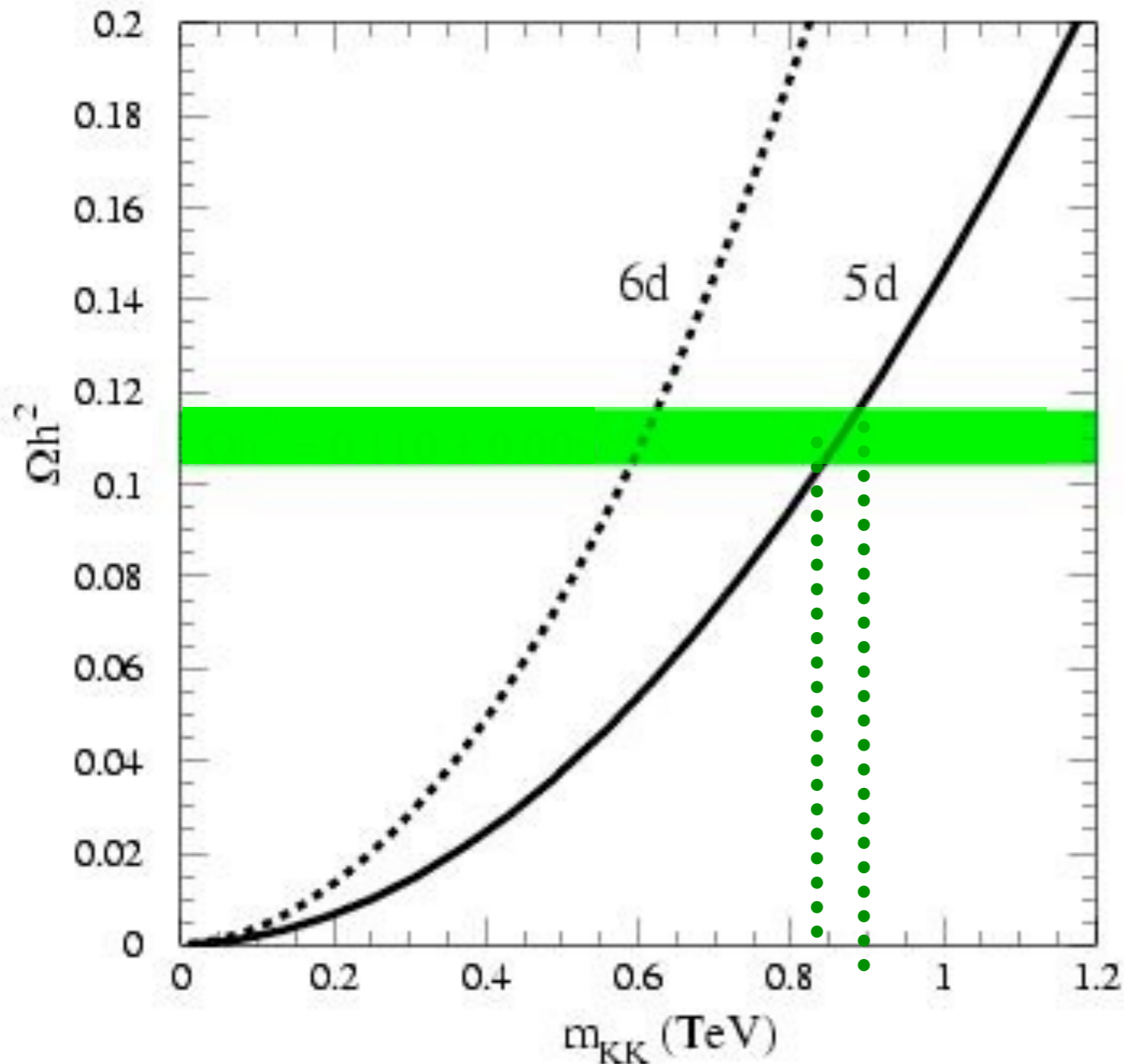

With no helicity suppression for annihilation, the LKP realizes the correct relic density for larger WIMP masses.

The 6d curve is for a 2-torus with equal radii (2 LKPs):

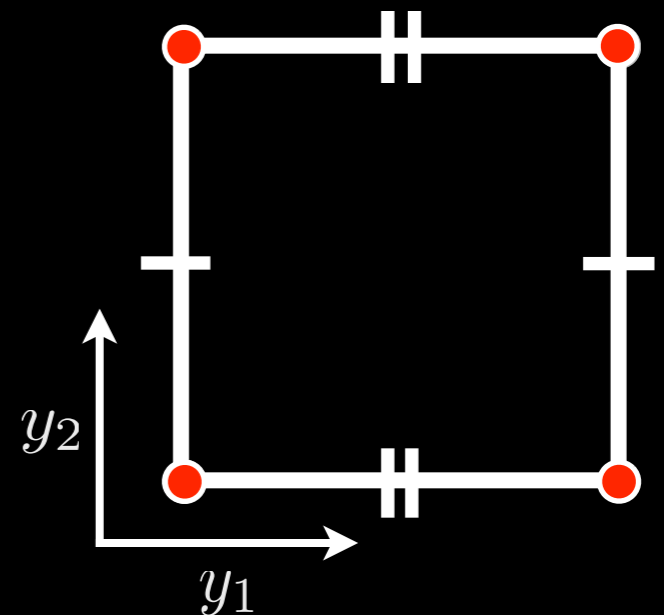

Co-annihilation

- Just like in SUSY, nearby particles can affect the relic density. In particular, we saw that the mass of $e^{(1)}_R$ is close to $B^{(1)}$ in mUED.
- However unlike SUSY, both particles interact with roughly with the same cross section, and the freeze-out temperature is basically unchanged,
- Some $e^{(1)}_R$ are left over after freeze-out, and eventually decay into $B^{(1)}$ and $e^{(0)}$. The net relic density of $B^{(1)}$ is increased, rather than reduced.

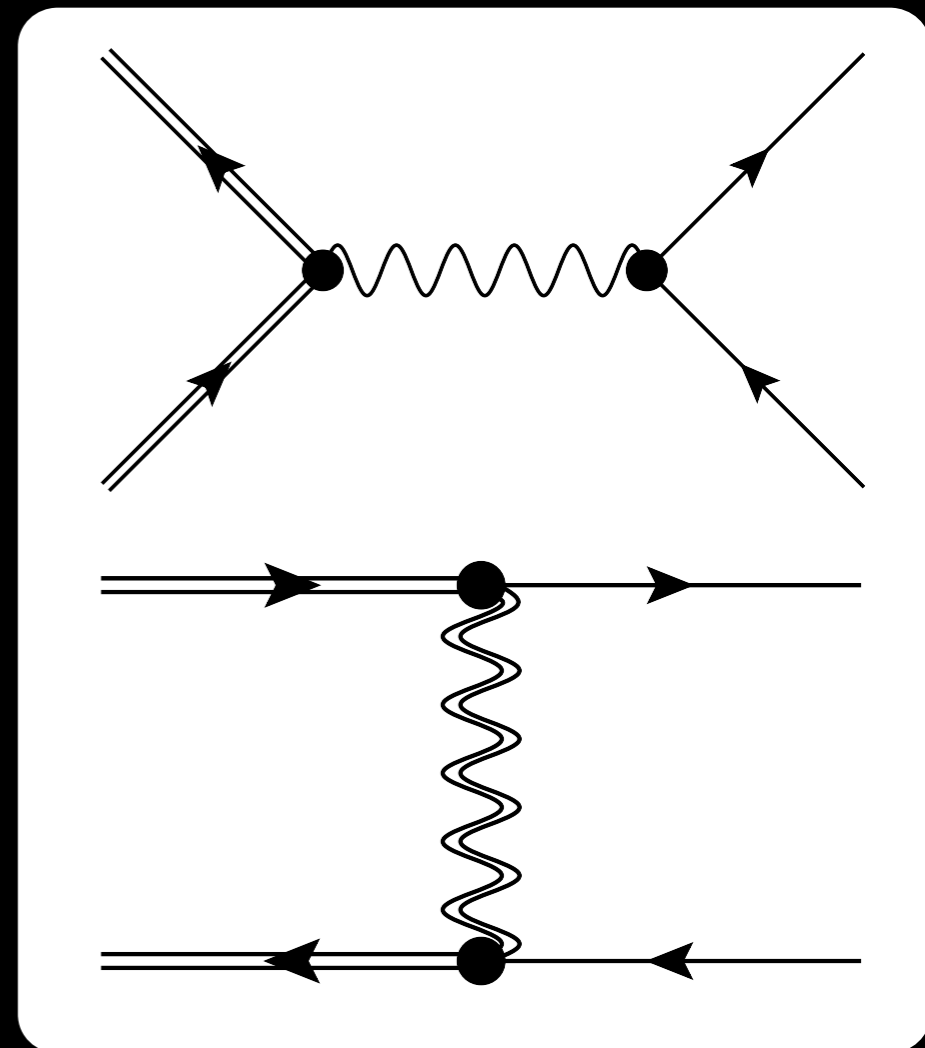
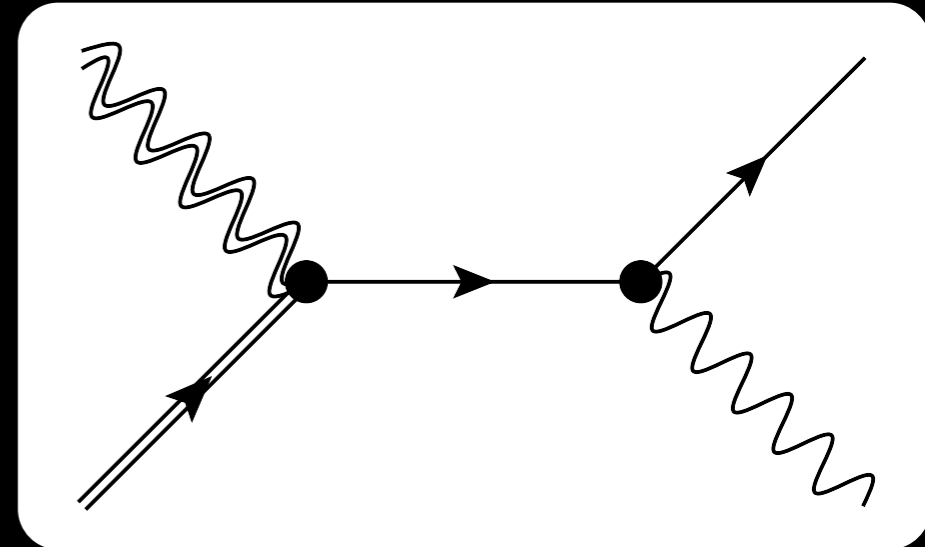

Relic Density with Co-annihilation

G. Servant, TMPT, NPB650, 351 (2003)

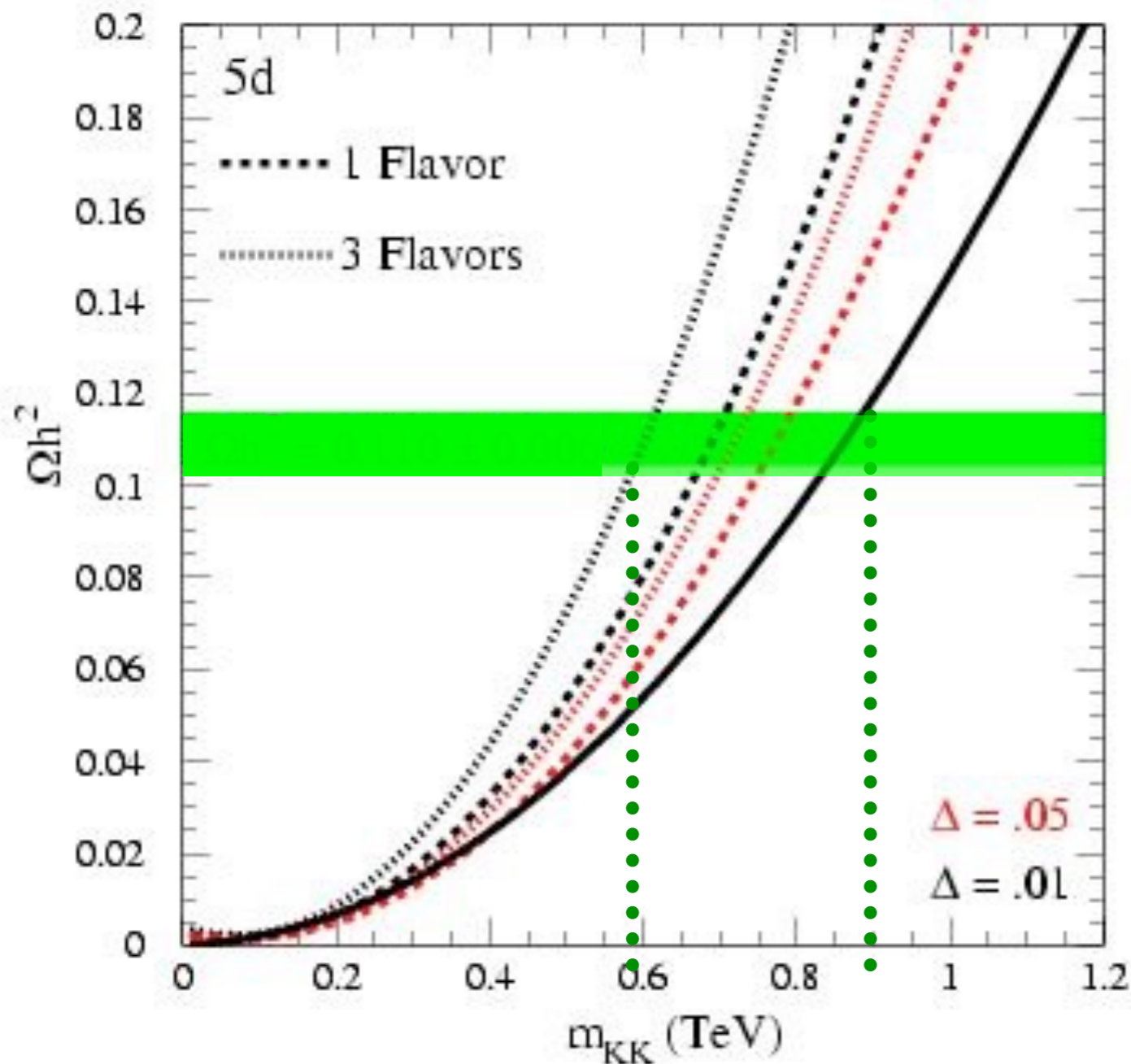

Coannihilation leads to an increase in the number of LKPs after freeze-out. To compensate, we dial down the mass of the LKP so that the correct energy density results.

Δ is the splitting between the $B^{(1)}$ and $e_R^{(1)}$ masses.

$$\Delta \equiv \frac{m_{e_R^{(1)}} - m_{B^{(1)}}}{m_{B^{(1)}}$$

Gamma Rays from UED

- There is a large rate for continuum γ 's with a harder (than, say, SUSY) spectrum, because the LKP likes to annihilate into e^+e^- .
- There are $\gamma\gamma$, γZ , and γ Higgs lines.
- Over-all, the lines are relatively faint, and tend to merge into the continuum photons from WIMP annihilations.
- Resolving them is possible for a very light LKP, and would require a next- (or next to next) generation gamma ray observatory.

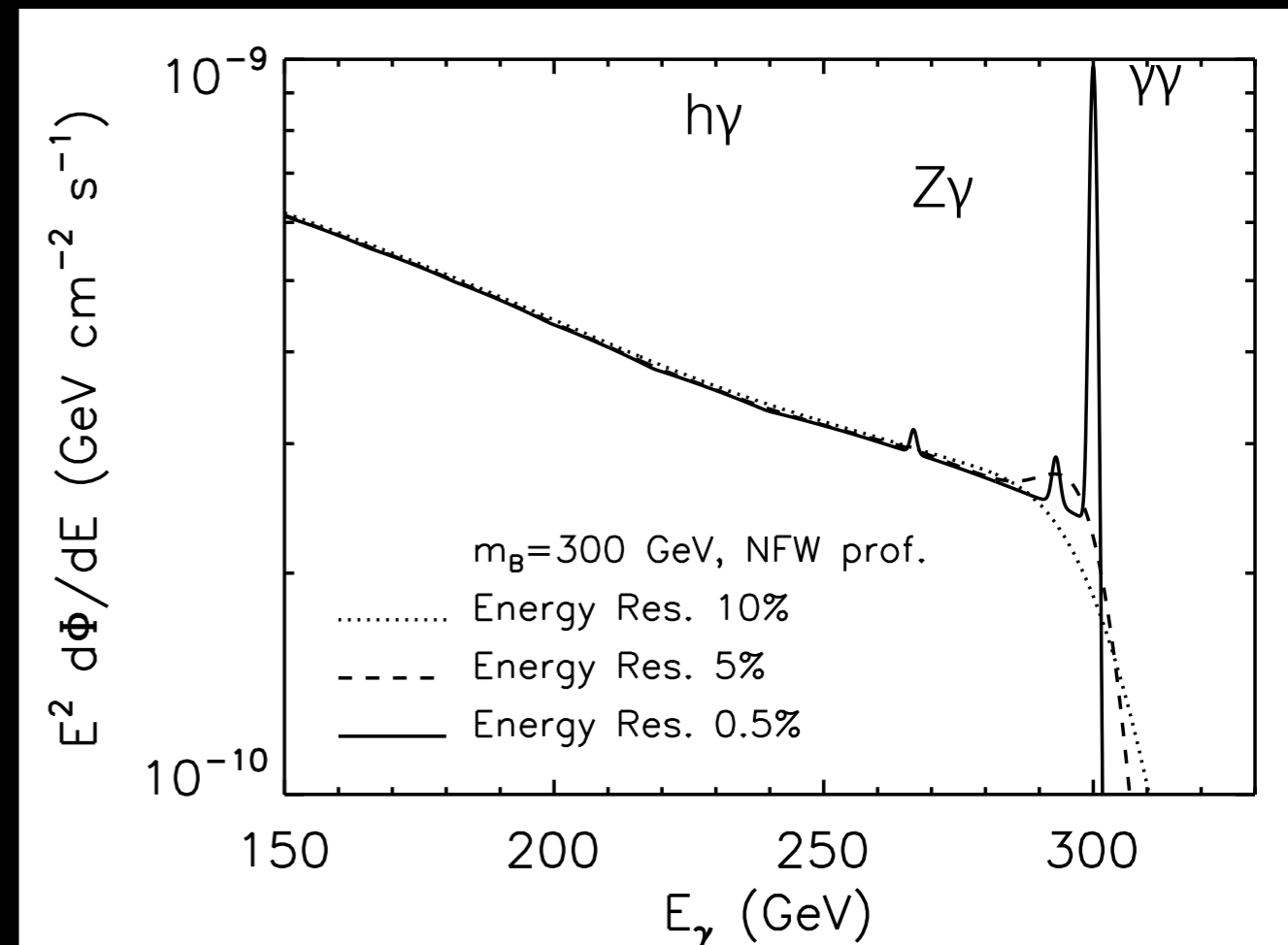

Bertone, Jackson, Shaughnessy,
TMPT, Vallinotto 1009.5197

Direct Detection

- Much like the case of SUSY models, UED dark matter interacts with nuclei largely by exchanging Higgs (zero mode) bosons.
- KK quarks also contribute, but are expected to be heavier and thus less important.

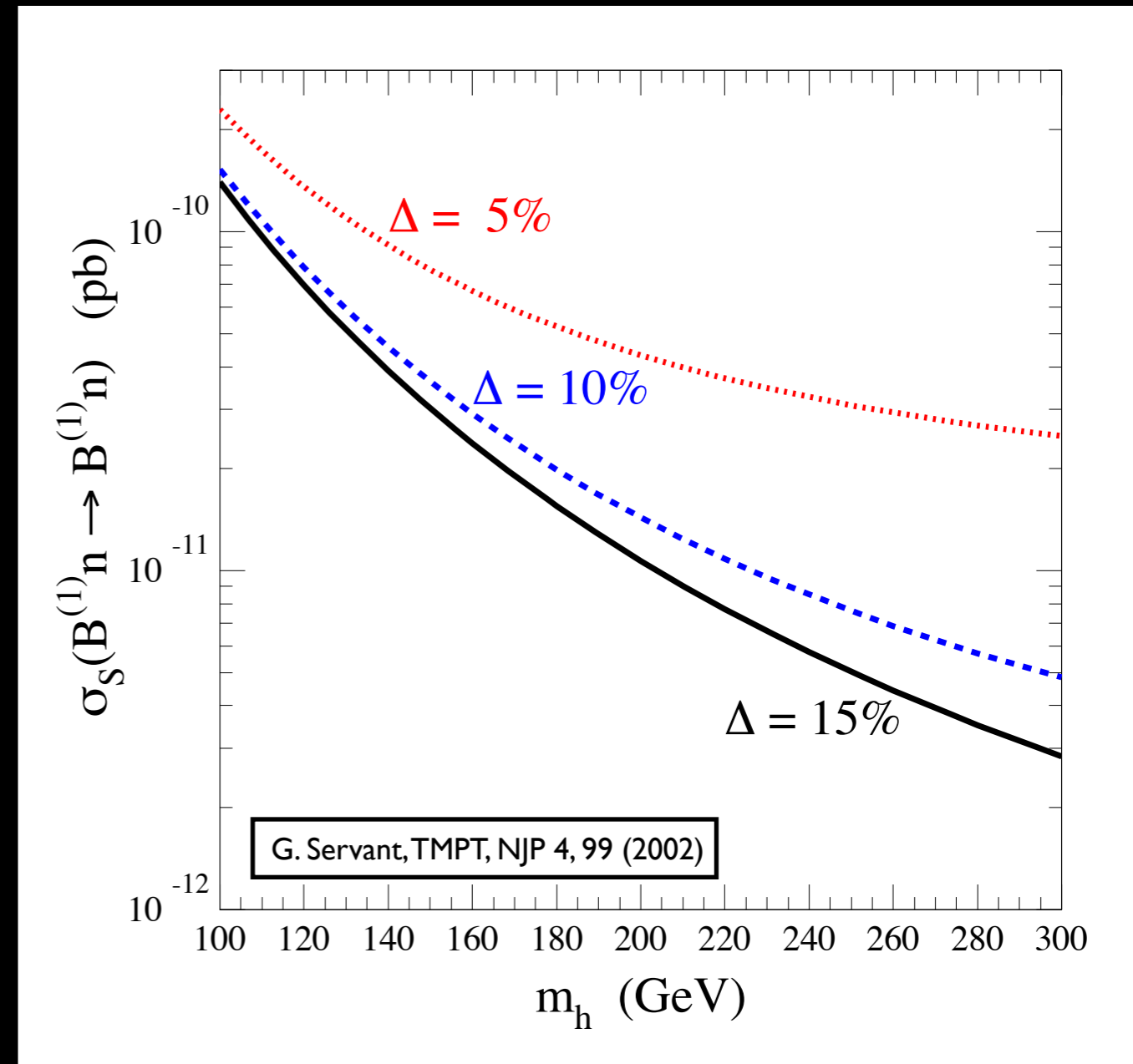
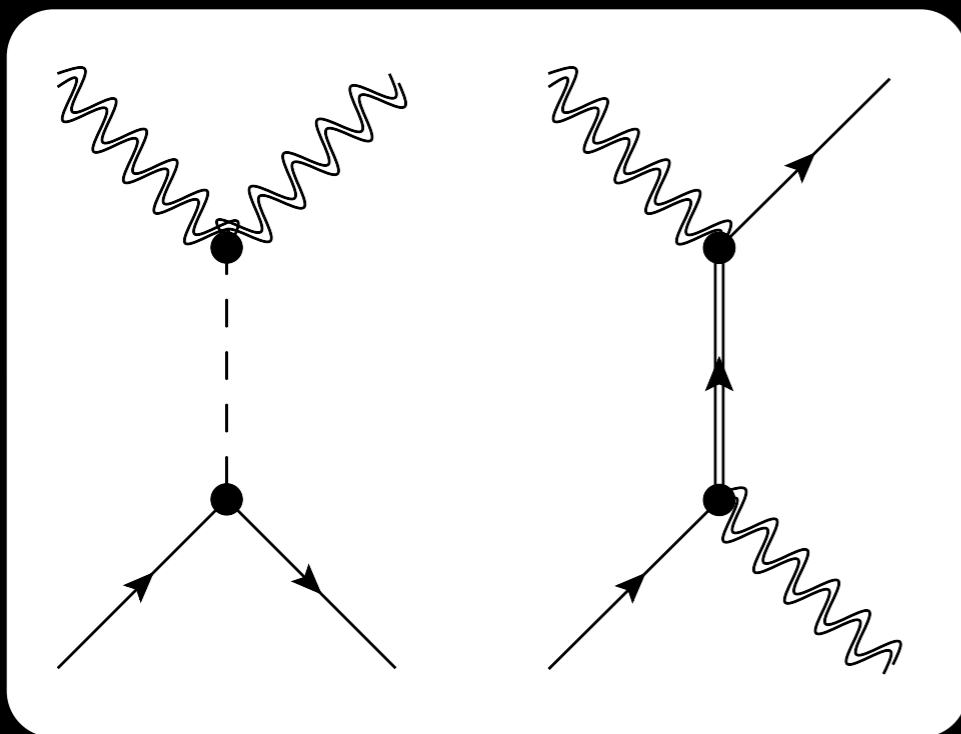

UED at the LHC

- At the LHC, one can expect cascade decays very much like we find in SUSY models, where we produce colored KK particles and they decay down through the weakly interacting ones into the LKP.
- This raises an interesting and important question: how do we measure the spins of particles when we can't observe some of their decay products directly?

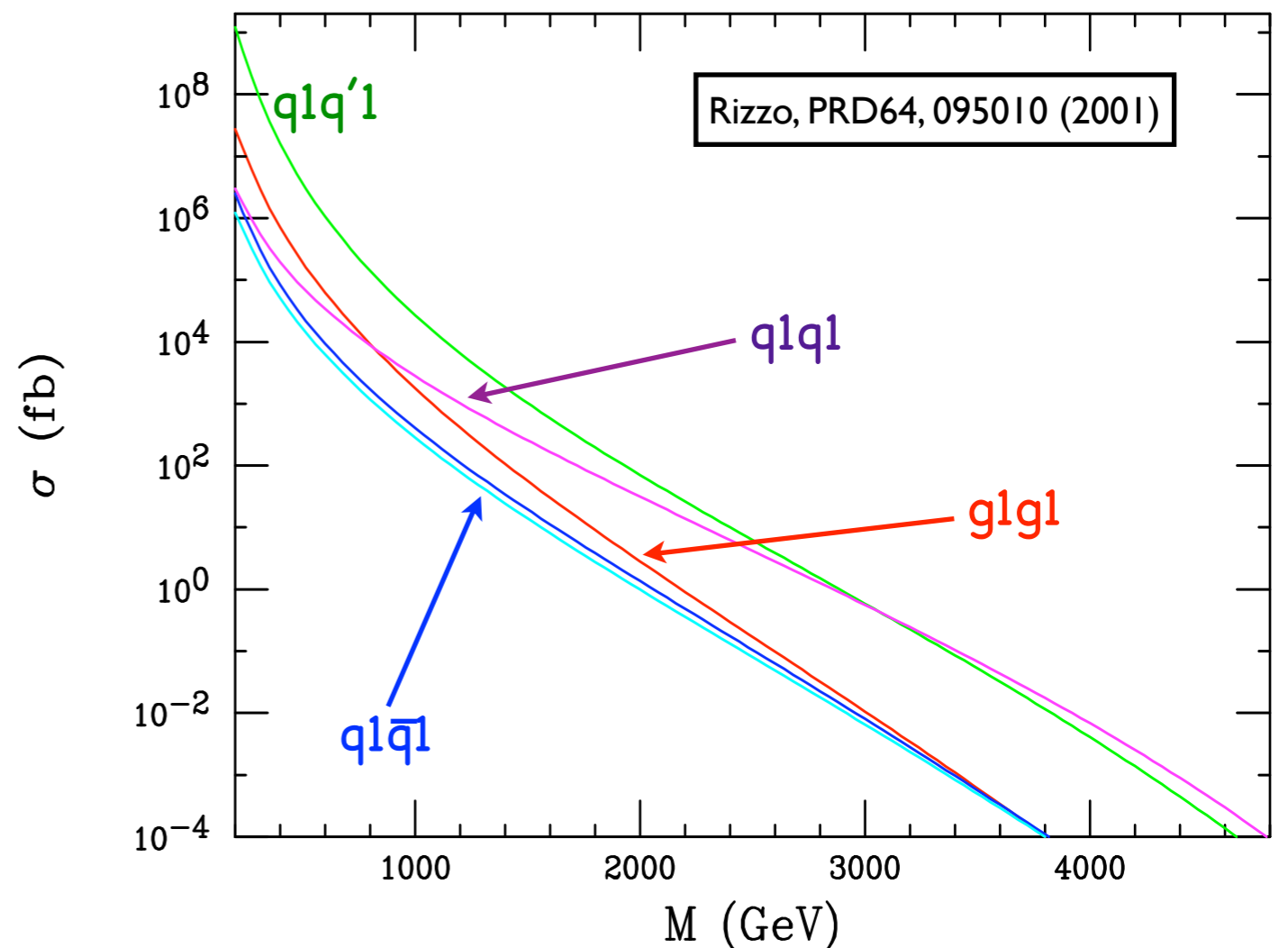
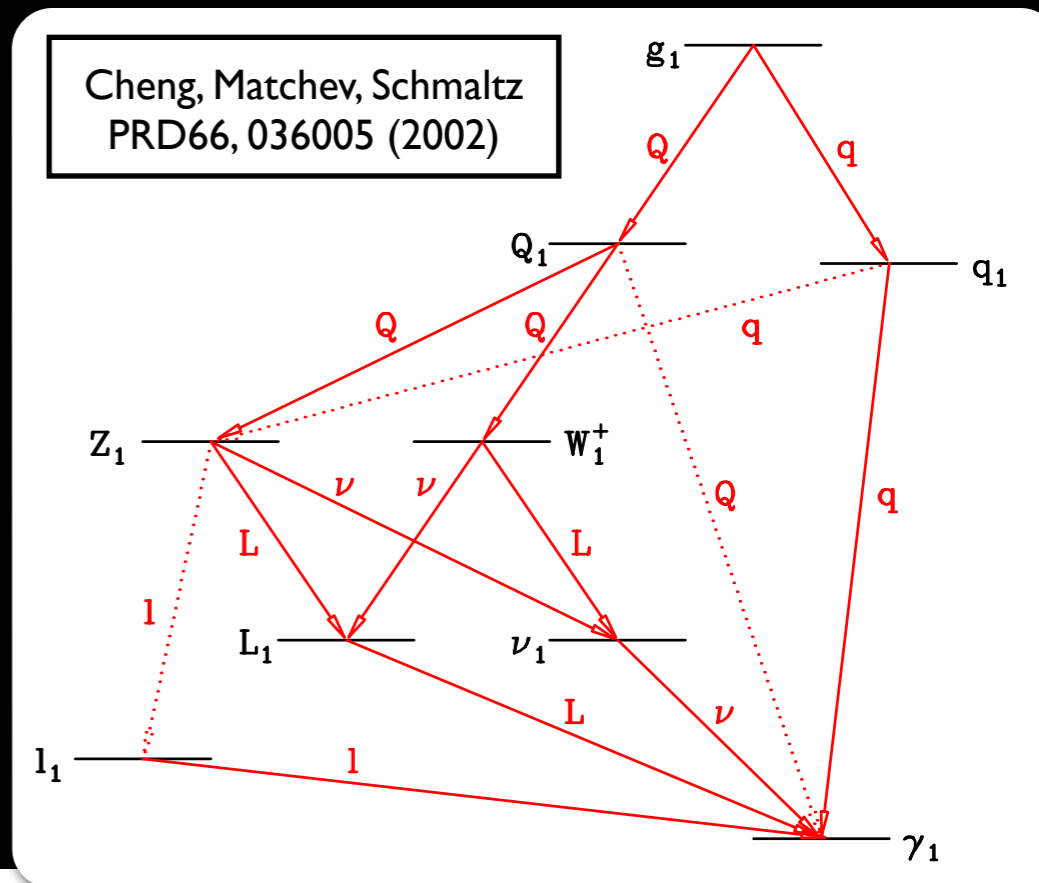

6d UED: The Chiral Square

- Let's look at another example of a 6d model. The Chiral Square is a UED theory with two extra dimensions.

Burdman, Dobrescu, Ponton '04, '05

- The adjacent sides are identified as the same, which can be visualized as a square region folded along a diagonal. This is another orbifold compactification with chiral fermions.

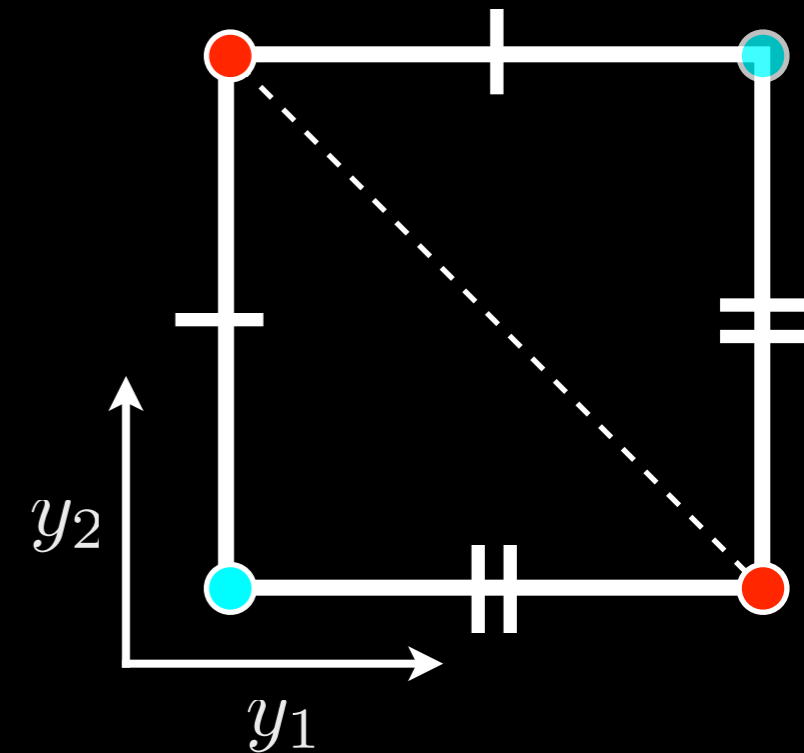

KK parity requires that two of the boundary terms at $(0,R)$ and $(R,0)$ are equal in size.

- There are three “fixed points”, where boundary terms can live which preserve KK parity.

- I'll follow the usual practice and assume the size of the boundary terms is consistent with their being generated by loops -- “minimal UED”.

Ponton, Wang '06

KK Decomposition

- In the case of a 6d UED model, KK modes are labelled by a pair of integers (j,k) indicating momentum flow in the extra dimensions.
- Masses are given (up to corrections from boundary terms) in terms of (j,k) :

$$M_{(j,k)}^2 \simeq \frac{1}{L^2} (j^2 + k^2)$$

- KK parity leaves the lightest of the $j+k = \text{odd}$ modes stable, providing our stable WIMP.
- The vector bosons have KK towers corresponding to 4d vector particles (which contain a zero mode) and a combination of the 5 and 6 components which looks like a 4d scalar (without a zero mode).

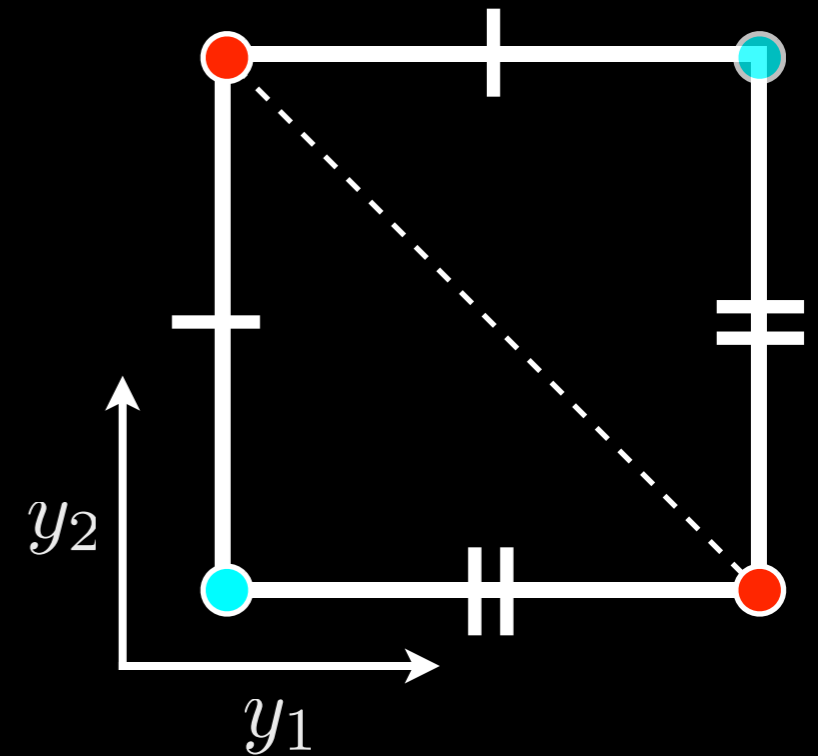

$$V_M \rightarrow \{V_\mu, V_5, V_6\}$$

One combination eaten by massive V_μ , the other combination is physical.

Spectrum

- As in the 5d theory, boundary terms modify the masses of the fields at a given (j,k) level.
- The LKP is usually the scalar $(1,0)$ KK mode of the Hypercharge gauge boson, B_H .
 - Colored states are the heaviest of a given (j,k) .
- The $(1,1)$ modes are KK even and many have masses above M_B but below $2 \times M_B$.

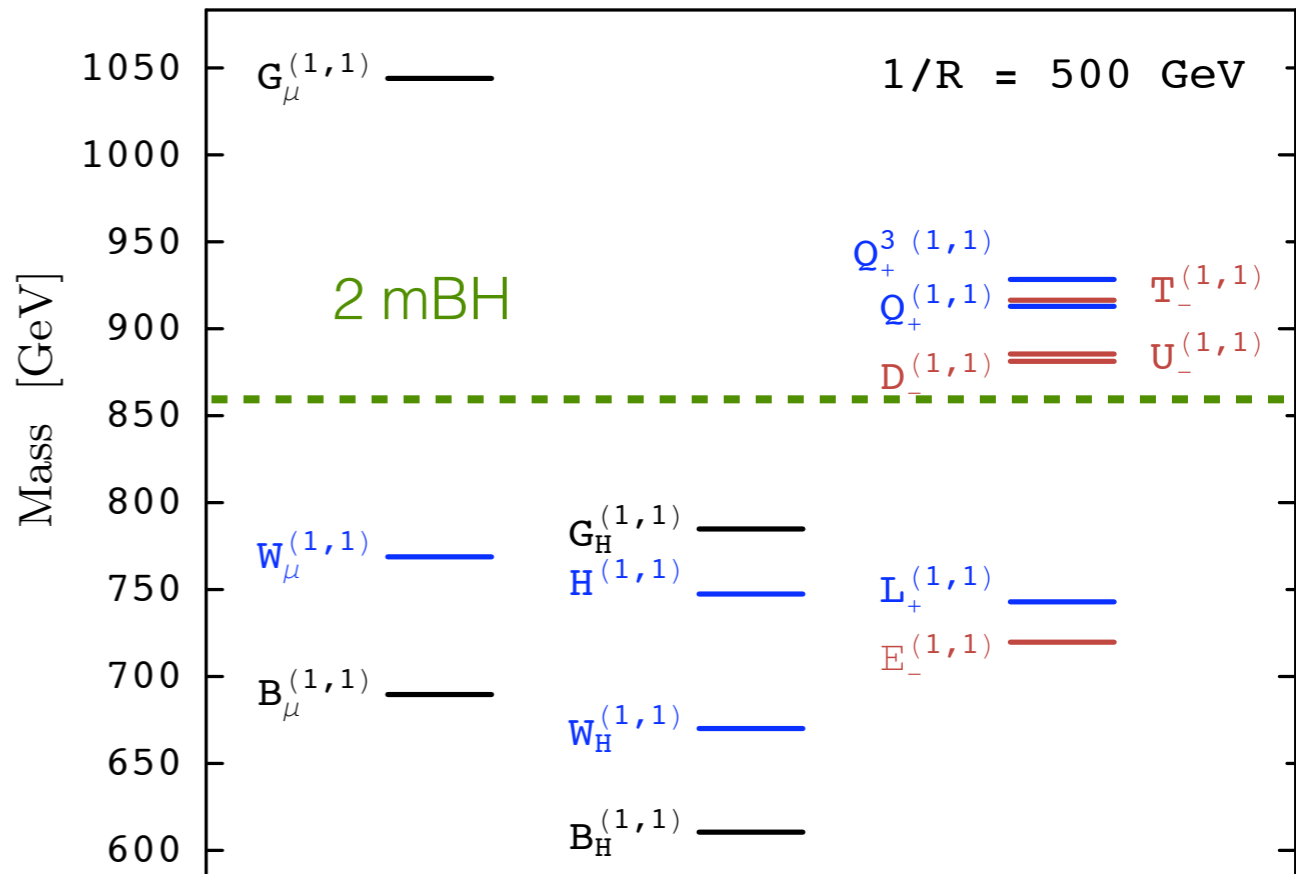
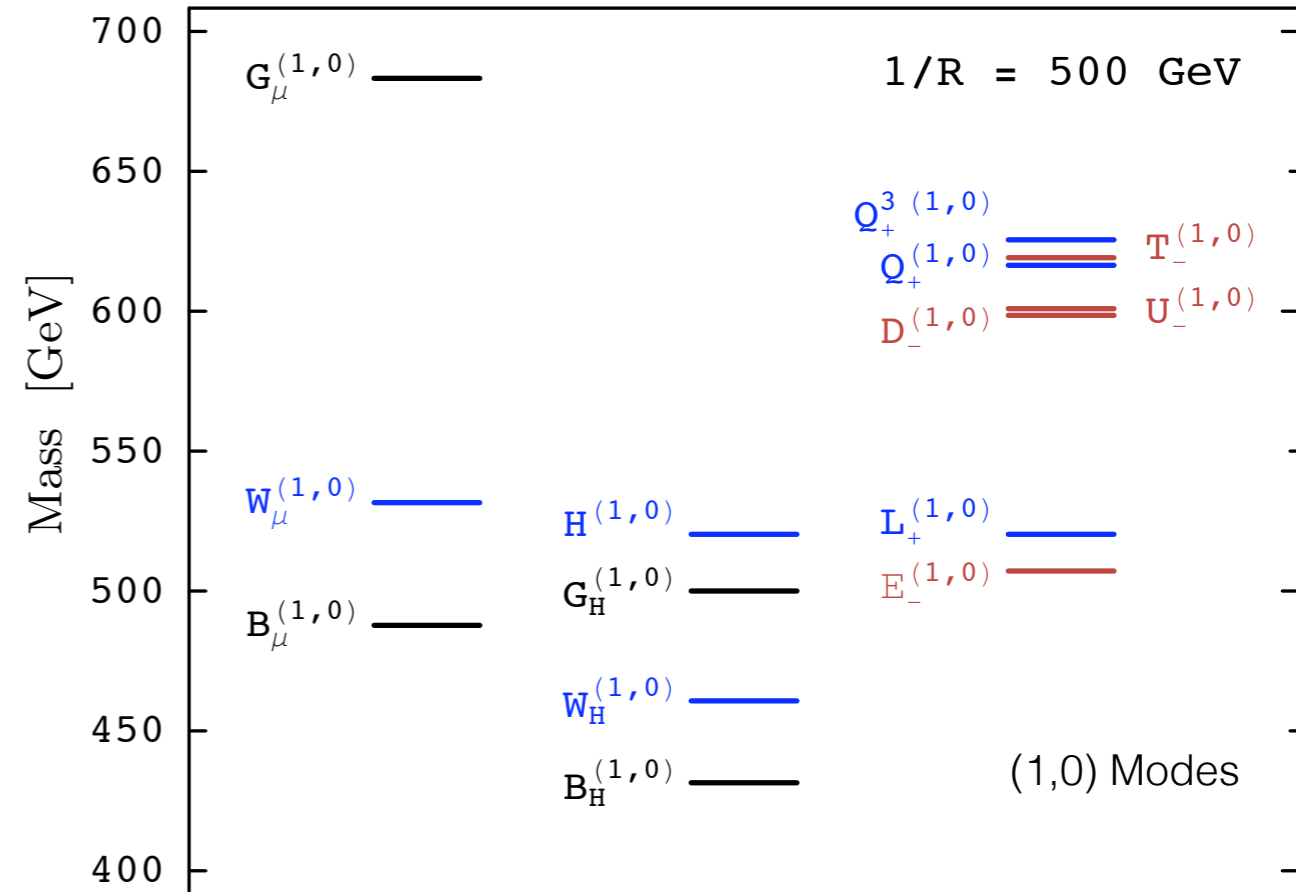

BH Annihilations

- Both the regions of parameter space and the continuum gamma ray emission spectra and rates are controlled by the tree level LKP annihilation channels.
- BH is a real scalar and an electroweak singlet:
 - BH BH into fermions is suppressed by the final state fermion mass (more like what we saw in the MSSM than the 5d UED model).
 - Annihilation into weak boson and Higgs pairs are mediated by the Higgs boson itself.

Dobresu, Hooper, Kong, Mahbubani, '07

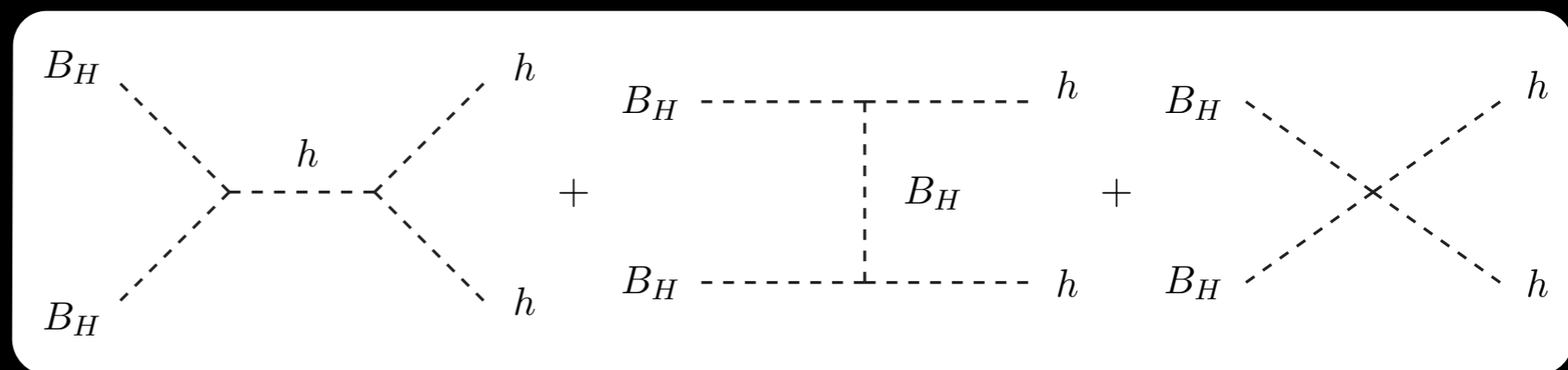
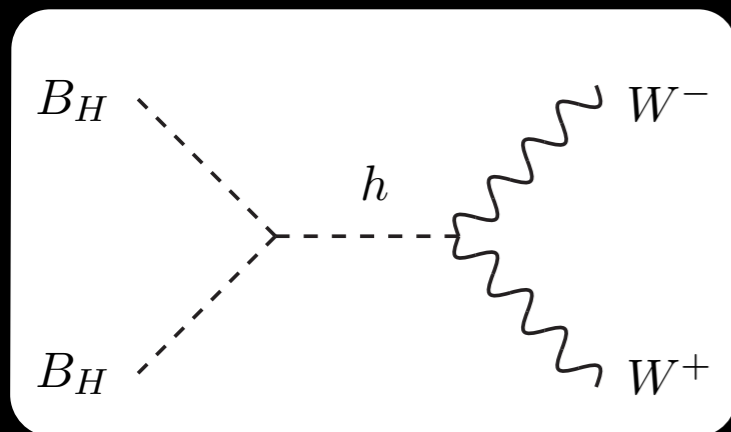

Relic Density

- Because of the s-channel Higgs-mediated graphs, the annihilation cross section is very sensitive to the interplay between the LKP and Higgs masses.
- This is another example of a funnel region, like the ones we saw in the MSSM.
- The Higgs discovery at the LHC has severely collapsed the parameter space down to LKP masses around 200 GeV.

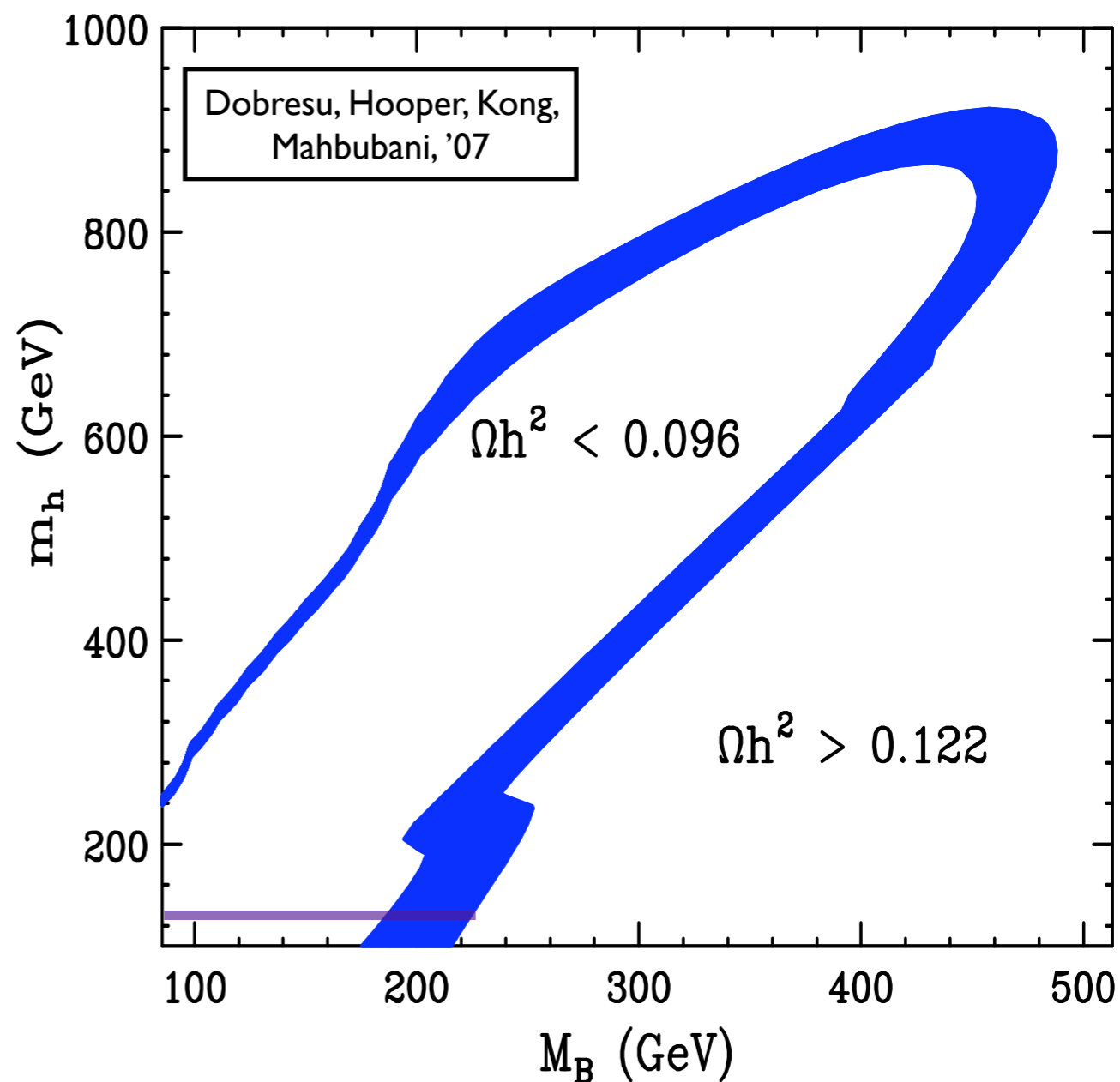
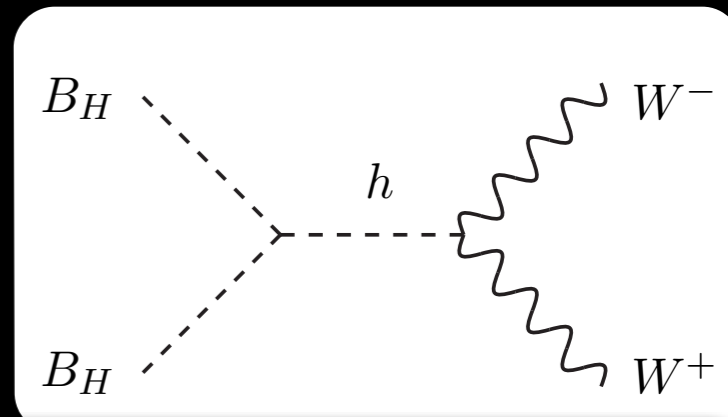

Chiral Square: γ -Rays

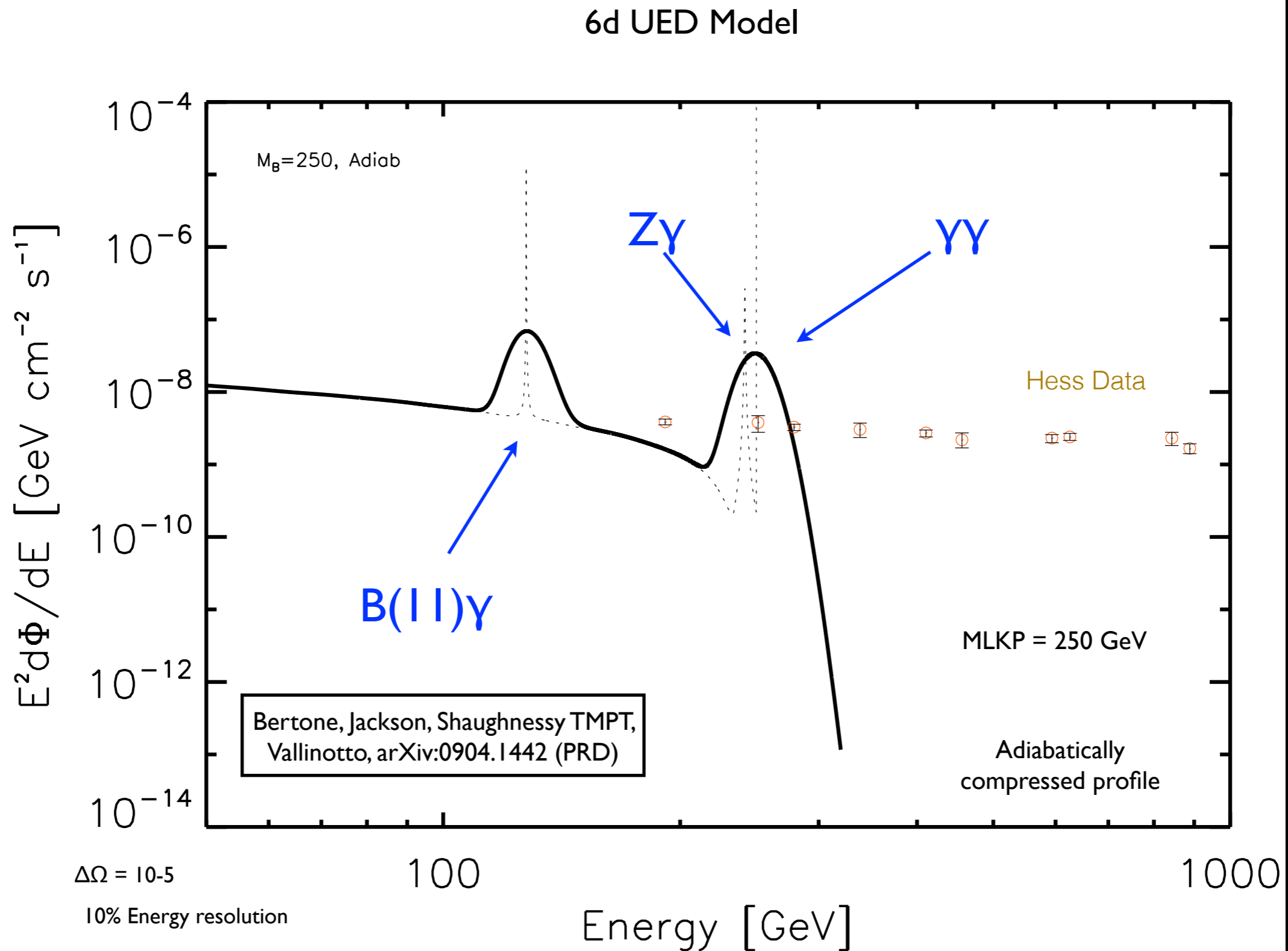

$B(1,1)$ at the LHC

- At the LHC, $B(1,1)$, can be produced from a $q \bar{q}$ initial state (with reduced but substantial couplings proportional to hypercharge).
- It decays into ordinary leptons and quarks, providing a classic Z' signature.
- γ -ray observations can observe the secondary line, and measure the mass - telling the LHC where to look.
- LHC data severely constrains the potential size of the brane terms, limiting the coupling of the $(1,1)$ state to zero mode (SM) fermions.

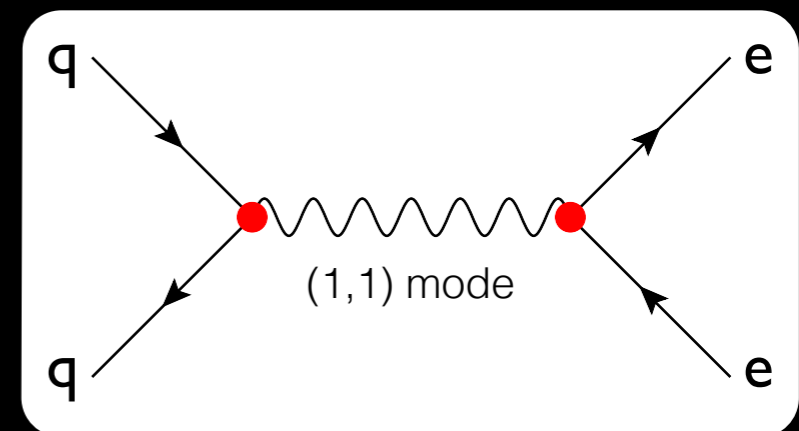
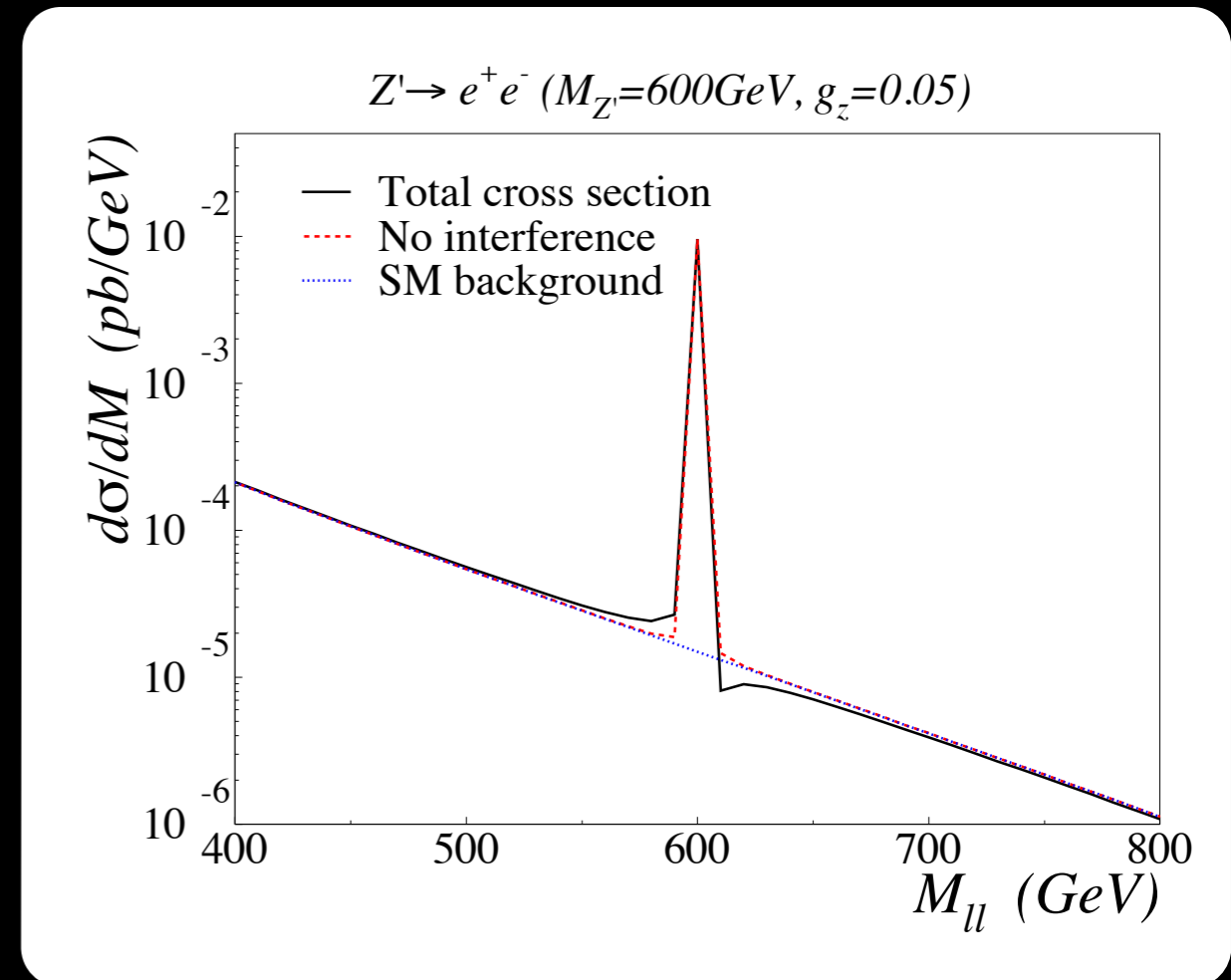

T-Parity

- Another symmetry which can stabilize dark matter is “T-parity”.

Cheng, Low hep-ph/0308199

- T-parity is a phenomenological symmetry which can be invoked to protect precision measurements from large contributions from new physics.
- If one requires the new particles to couple in pairs, they can't contribute to SM processes at tree level, and first appear at loop level.
- This implies the lightest new particle is stable.
 - R-parity and KK-parity are both examples!
- We can still address the hierarchy problem which, as you know from Michael's lectures, is a problem with loop diagrams.

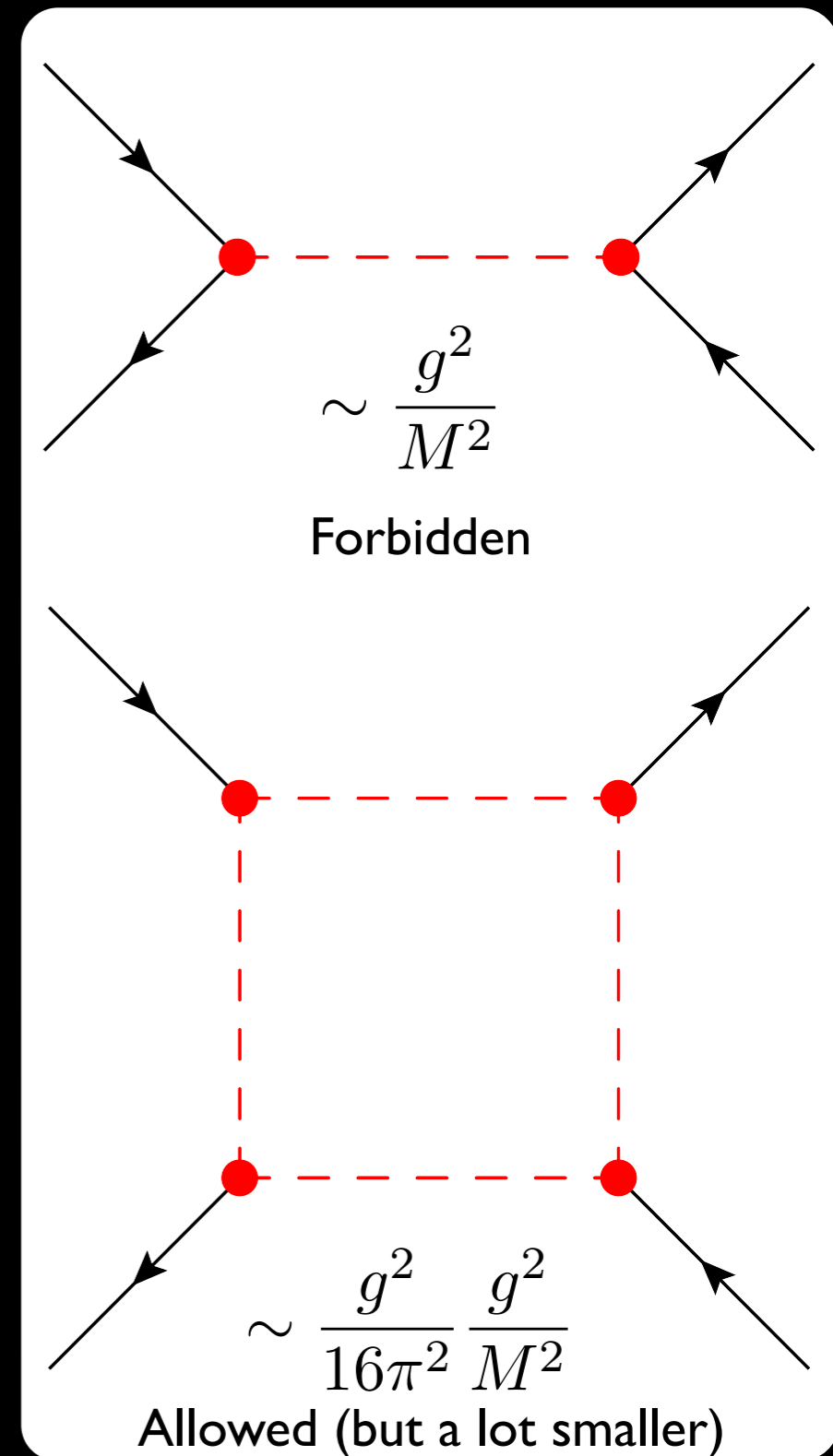

Little Higgs with T-parity

- Little Higgs theories attempt to create a gap between whatever stuff solves the hierarchy problem and the Higgs itself by engineering the Higgs to be a pseudo-Goldstone boson.
- It's a very nice idea, but it faltered in practice when it was found that precision electroweak data made it difficult to realize in practice.
- T-parity allows the extra new particles ("partners") to have light enough masses to make the Little Higgs idea workable.

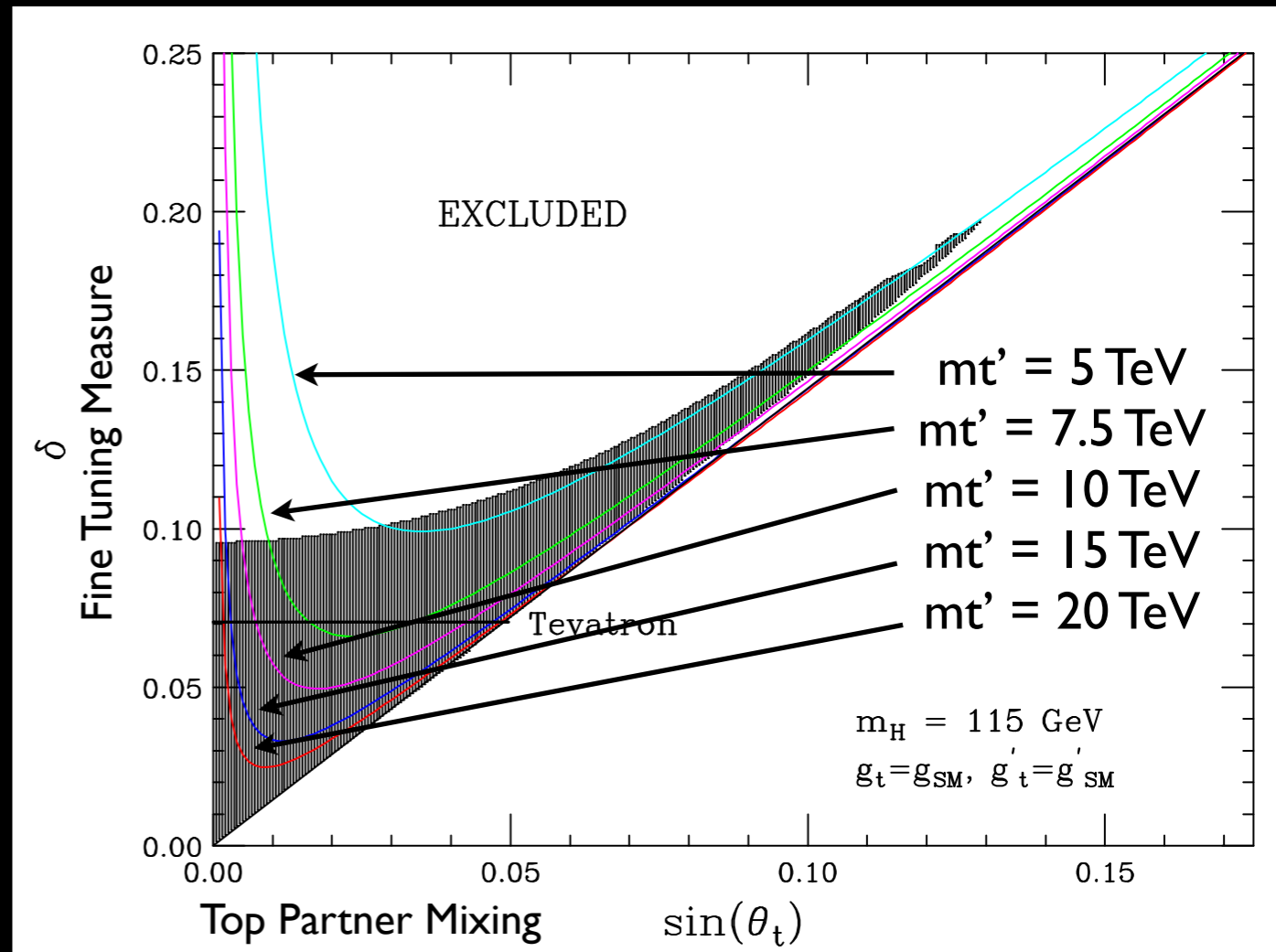

$$\delta \equiv \frac{v}{f}$$

Hewett, Petriello, Rizzo
 hep-ph/0211218
 See Also: Terning et al
 hep-ph/0211124

Less fine-tuned theories result,
 with new states coupling in pairs --
 the Lightest T-odd Particle is DM!

LTP

- A simple LH model with dark matter is the “Littlest Higgs with T-parity”.
- The lightest particle is often a $U(1)$ gauge boson, very similar to the LKP.
- The key difference is that the model only needs light partners for particles which couple strongly to the SM Higgs.
 - The t, W, Z, h partners are all light.
 - All other partners are assumed very heavy.
 - As a result, the cross section away from the SM Higgs funnel is always way too small to give us the correct relic density for a Standard Cosmology.
- This simplest model is ruled out by the LHC because the SM Higgs is too light.

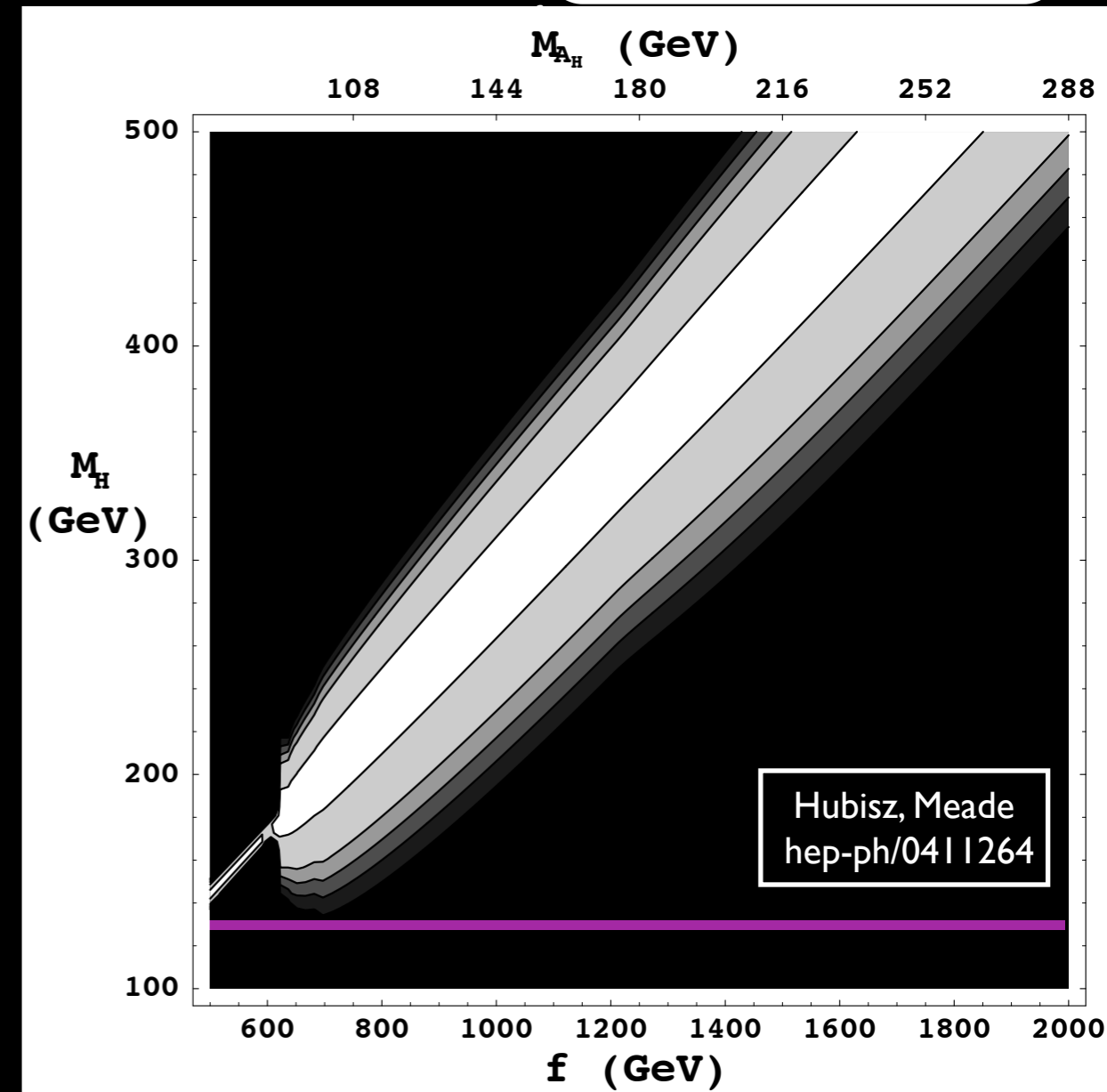
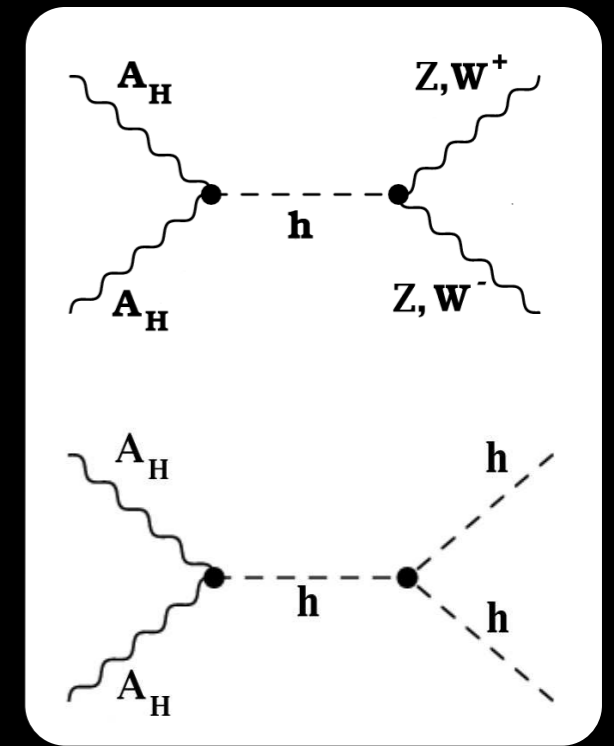

LHC Signals

- The LHC signals are dominated by the light colored partner (the top-partner).
- It turns out there are two:
 - A T-odd one which decays into $t + LTP$.
 - A T-even one which decays to $W + b$, $Z + t$, and/or $h + t$.
- The cross section for pair production of the top partners is QCD : depends on the mass & α_S .
- Single production of the T-even partner can dominate.

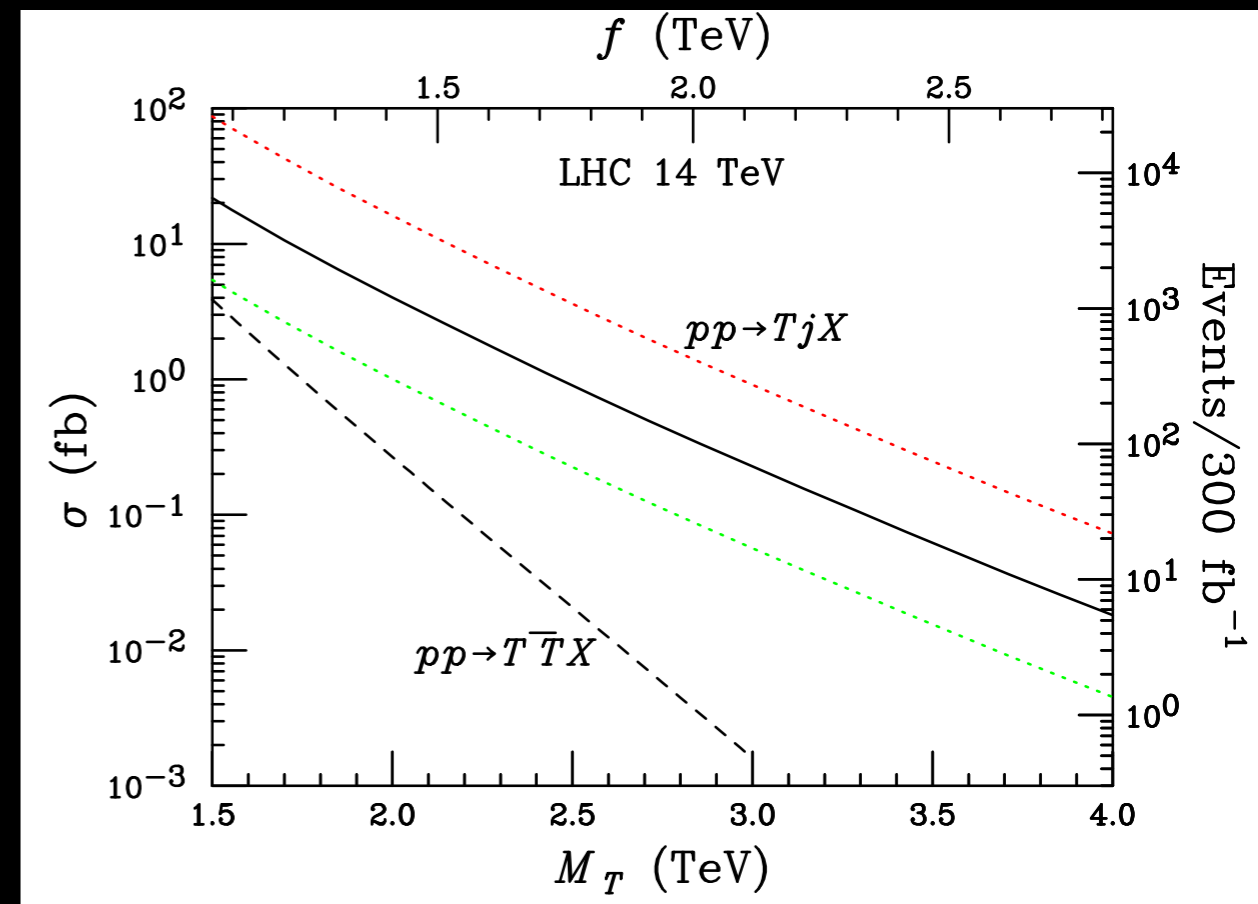
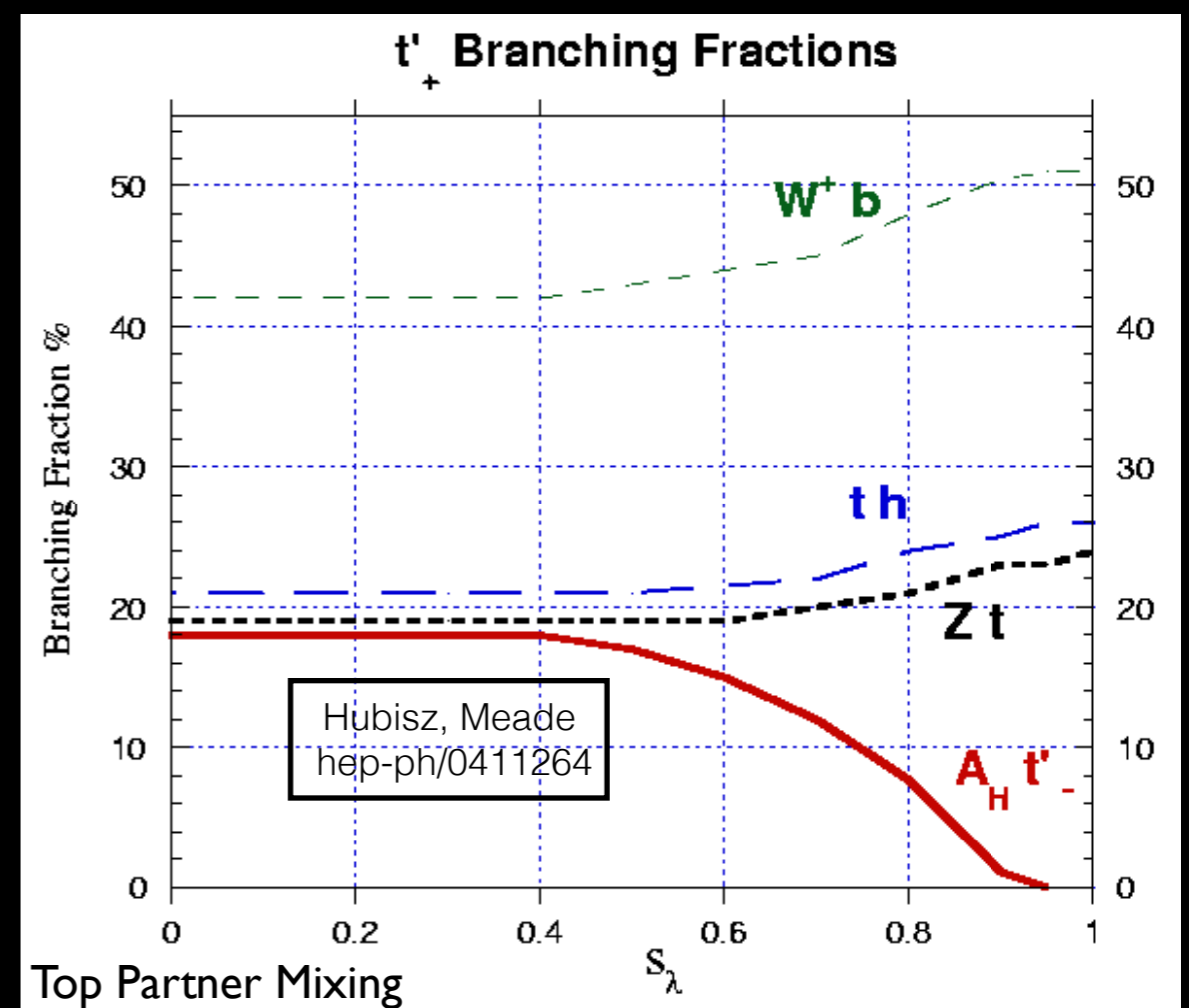

Han, Logan, McElrath, Wang
hep-ph/0301040

Super-WIMPs

- Dark matter could be super-weakly interacting.
- This gives up the beauty of the WIMP miracle, but is still an interesting possibility.
- In fact, both SUSY and UED theories naturally have a particle which could be dark matter and falls into this category:
 - SUSY: spin 3/2 gravitino
 - UED: spin 2 KK graviton
- I'll focus on the gravitino here, but the generalization to the KK graviton is rather straightforward.

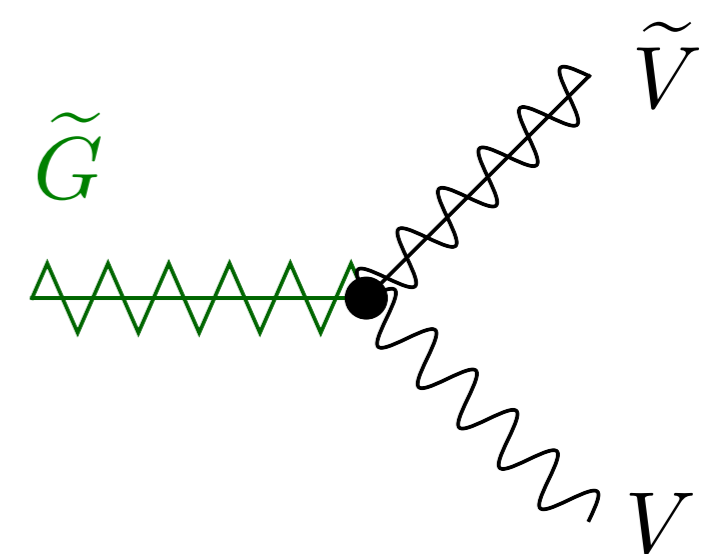

$$\sim \frac{M_{\tilde{V}}}{F} \sim \frac{M_{\tilde{V}}}{m_{\tilde{G}} M_{\text{Pl}}}$$

Dominant Coupling through the Goldstino component

For more UED details, see:
Feng, Rajaraman, Takayama
hep-ph/0302215 & 0307375

Relic Gravitinos

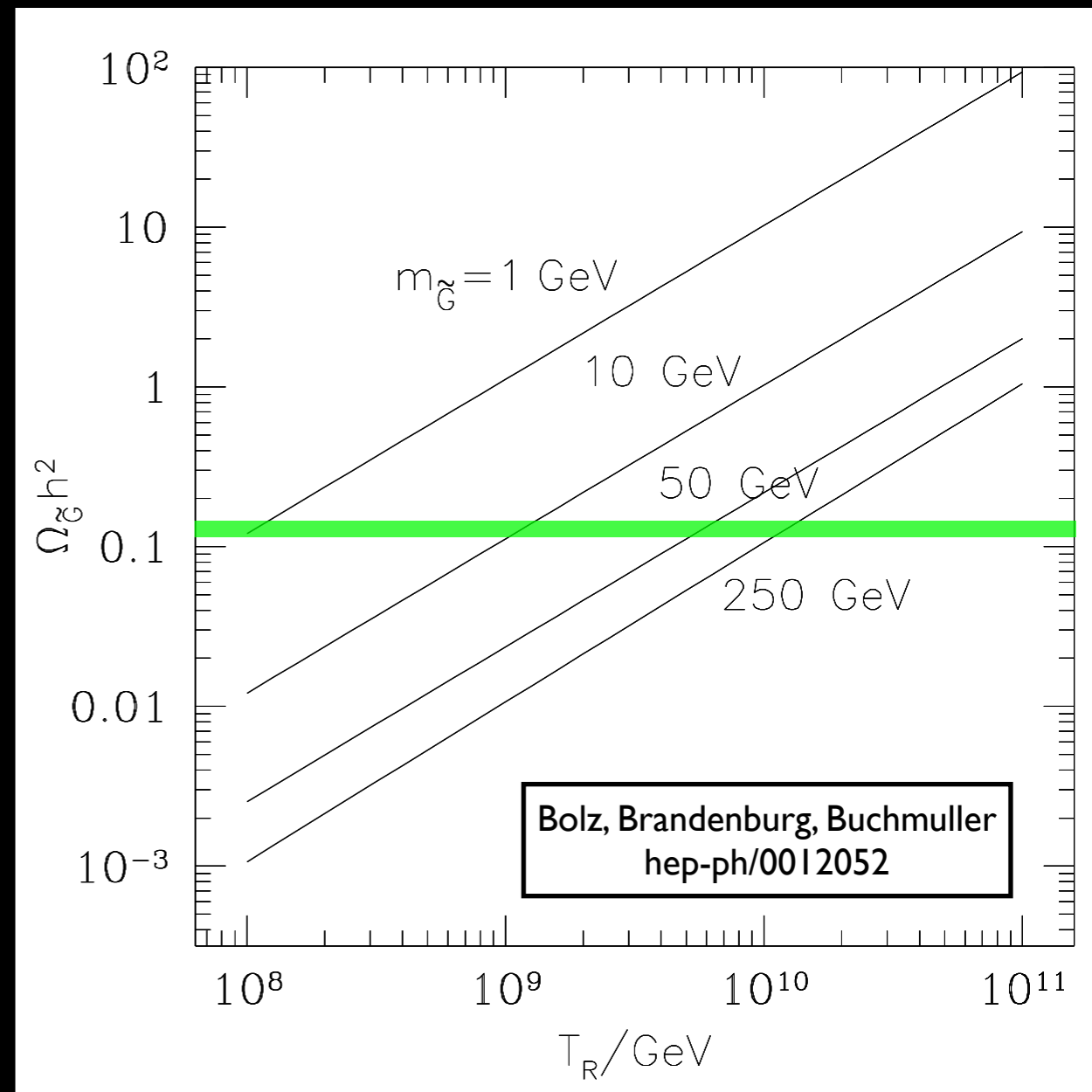
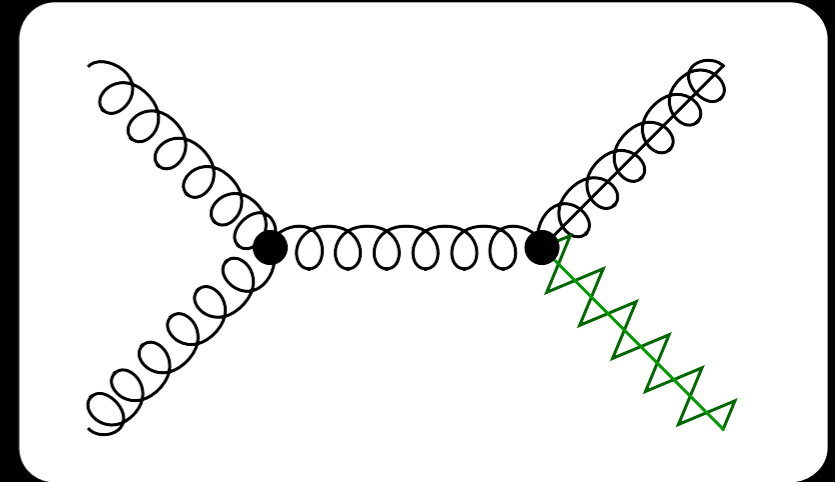
- Though they are never in equilibrium, we can still produce relic gravitinos:
- One mechanism is to have them *freeze-in*.
- Since they fail to reach equilibrium, the quantity generated depends very sensitively on the reheating temperature at the end of inflation.
- This can be a problem -- if they are overproduced, we can end up with too much dark matter, leading to a bound on T_R .
- For just the right T_R , we get $\Omega h^2 \sim 0.1$.



Late Decay

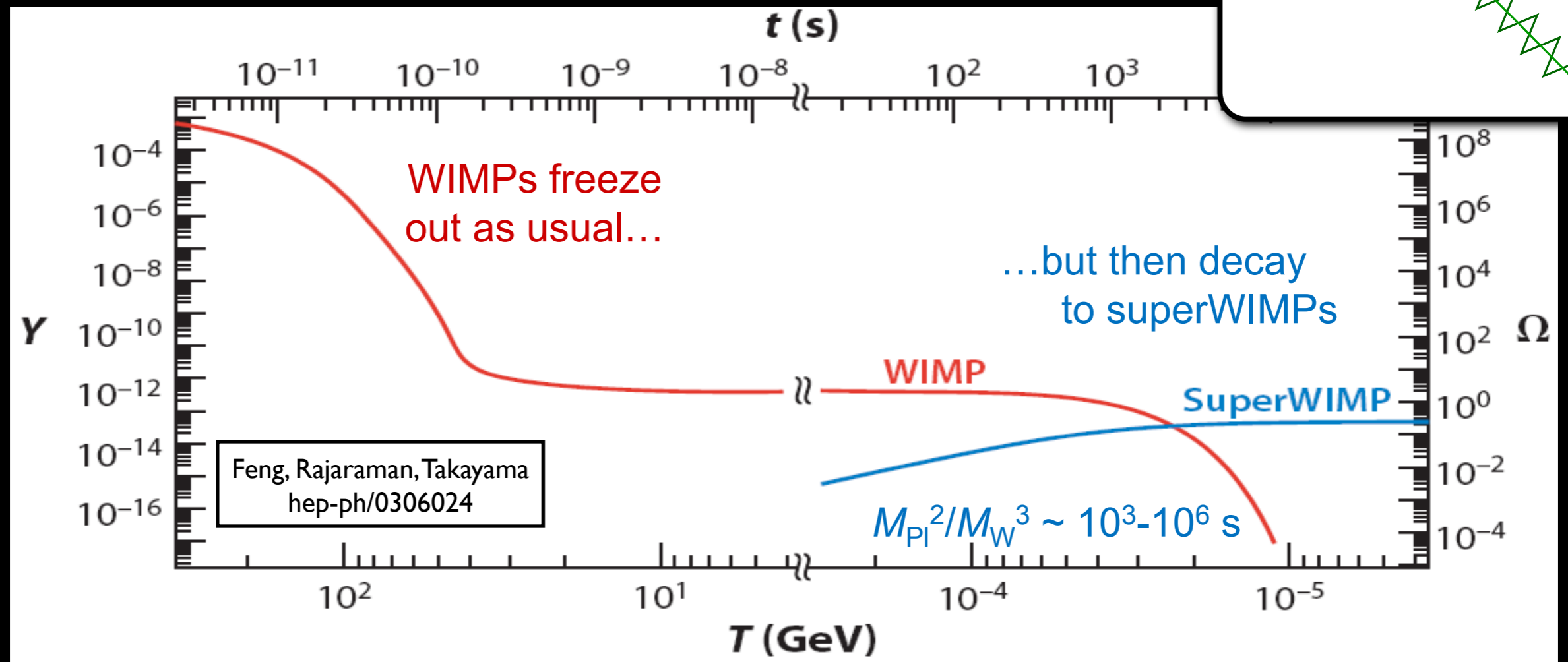
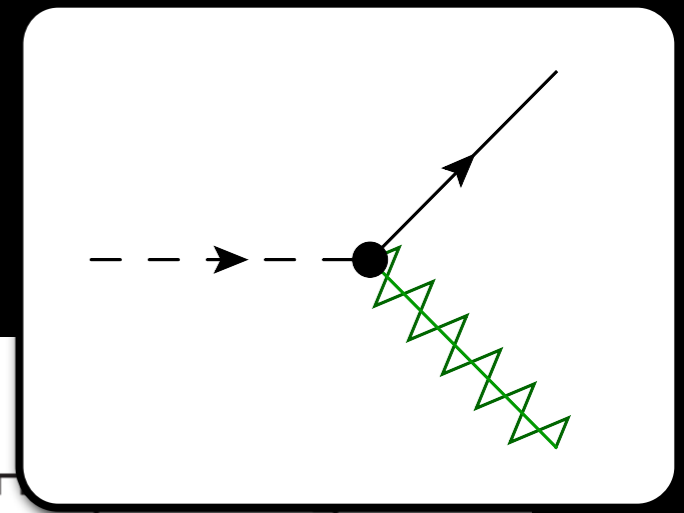

- A gravitino LSP can also be produced by the late decay of a more conventional WIMP, inheriting its relic density.
- The NLSP need not even be neutral!
- Some care is needed to have the decay not destroy light elements.

Axion Dark Matter

- As we learned from Michael, the axion is motivated by the strong CP-problem, where the QCD θ term is cancelled by introducing a scalar field -- the QCD axion.

Peccei, Quinn '77

- The axion's mass and coupling are determined by virtue of its being a pseudo-Goldstone boson and are characterized by the energy scale $f_a > 10^9$ GeV.

$$m_a \sim f_\pi / f_a \times m_\pi$$

Preskill, Wise, Wilczek '83
Abbott, Sikivie '83
Dine, Fischler '83

- The axion is unstable, but its tiny mass and weak couplings conspire to predict that for much of the viable parameter space its lifetime is much greater than the age of the Universe itself.
- More generally, string theories often contain axion-like particles which are long-lived and can play the role of dark matter but have less tight correlations between their masses and couplings.

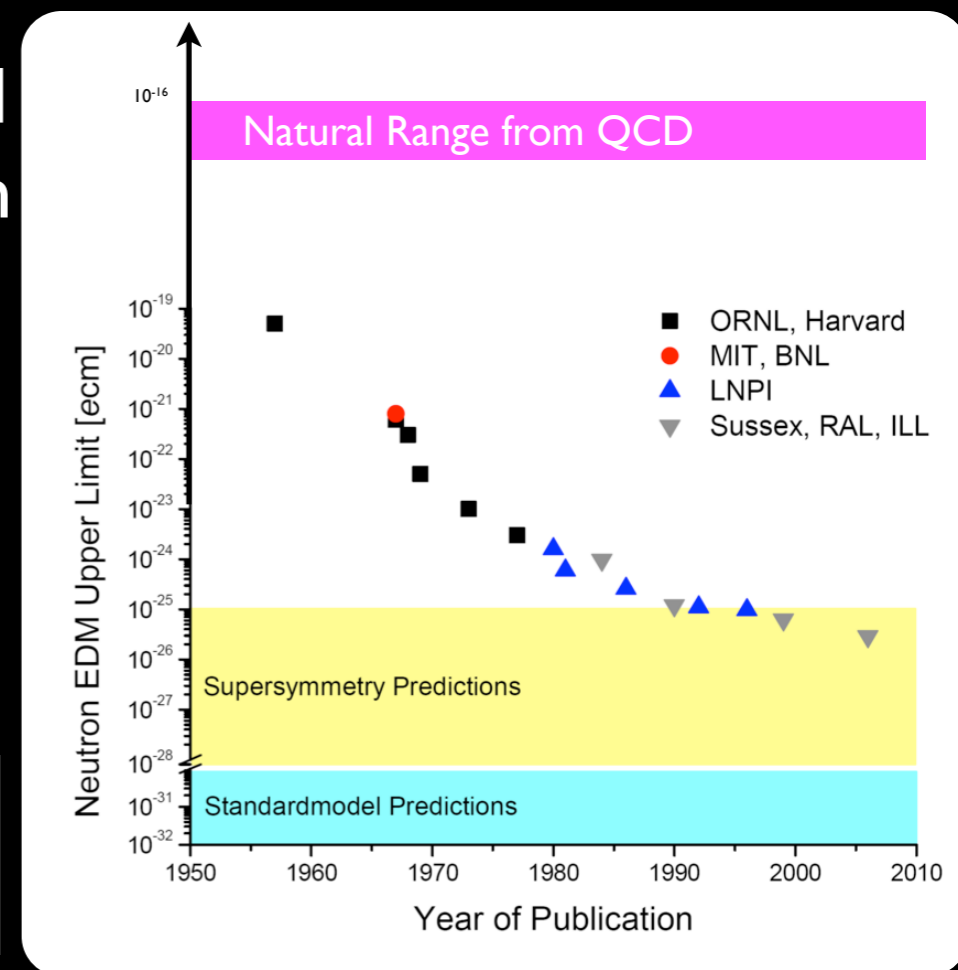

Axion Conversion

- The axion has a model-dependent coupling to electromagnetic fields that is somewhat smaller than $1 / f_a$.
- There is a rich and varied program of axion searches based on this coupling.
- One particular search looks for ambient axions converting into EM signals in the presence of a strong background magnetic field.
- Other very interesting new ideas are to look for time variation in the neutron EDM or the induced current in an LC circuit.

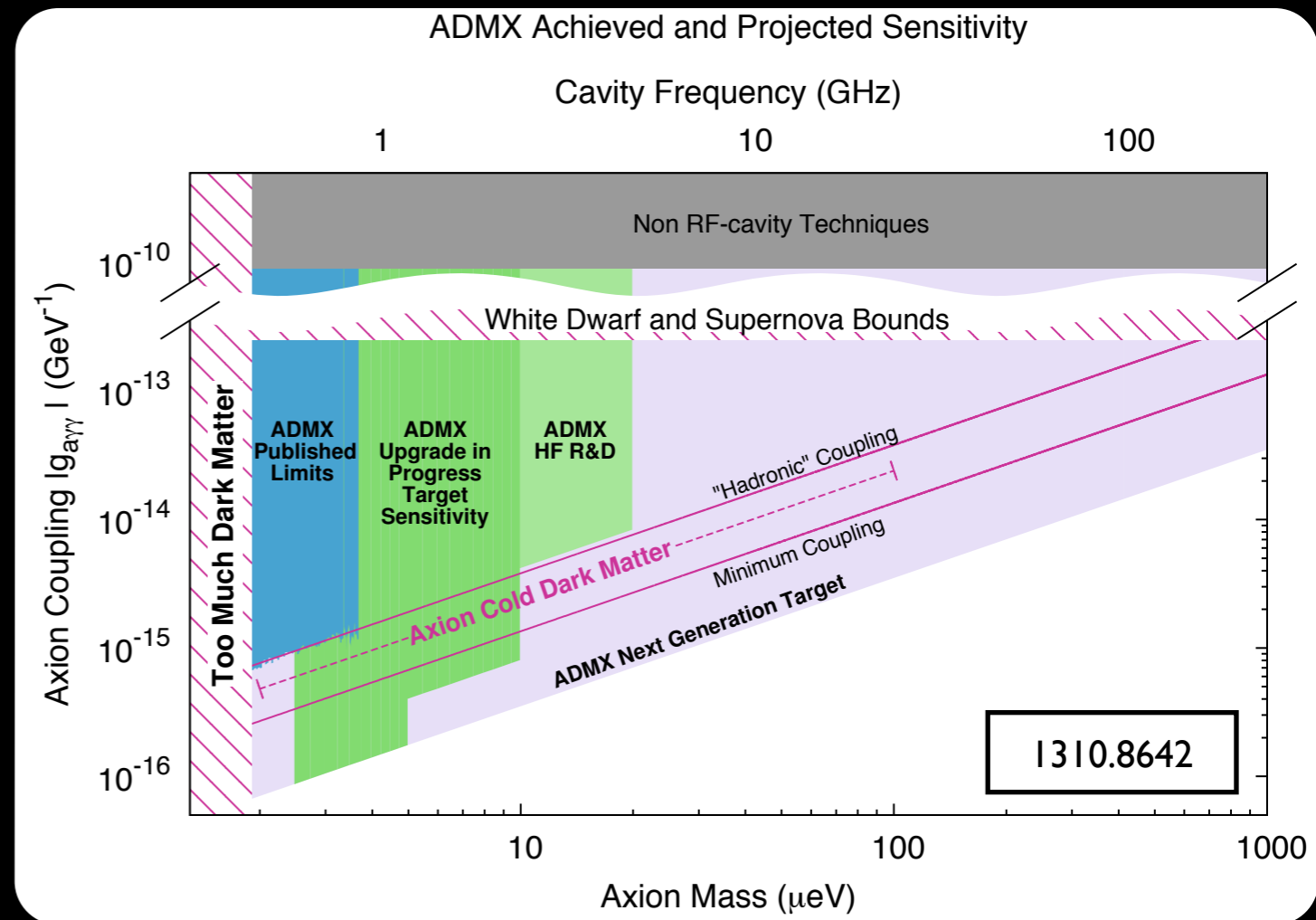

Axion dark matter can be produced by a misalignment mechanism, in which its original value at the time of inflation converts into a particle density once its mass turns on.

Sterile Neutrino DM

- Dark matter may be connected to one of the other incontrovertible signals of physics beyond the SM: neutrino masses.
- The simplest way to generate neutrino masses in the SM is to add some number of gauge singlet fermions to play the role of the right-handed neutrinos.
- If the additional states are light and not strongly mixed with the active neutrinos (as required by precision electroweak data), they can be stable on the scale of the age of the Universe and play the role of dark matter.
- Arriving at the right amount of dark matter via oscillations typically requires delicately choosing the mass and mixing angle, or invoking some other new physics.

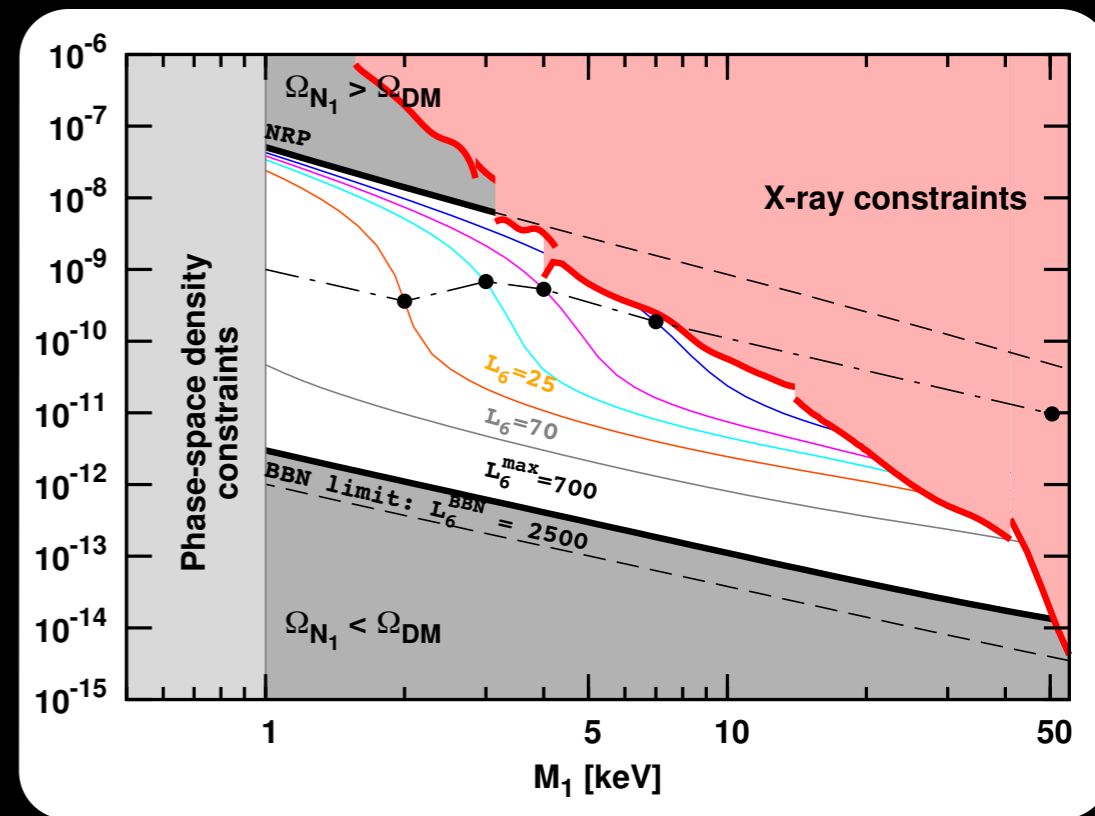
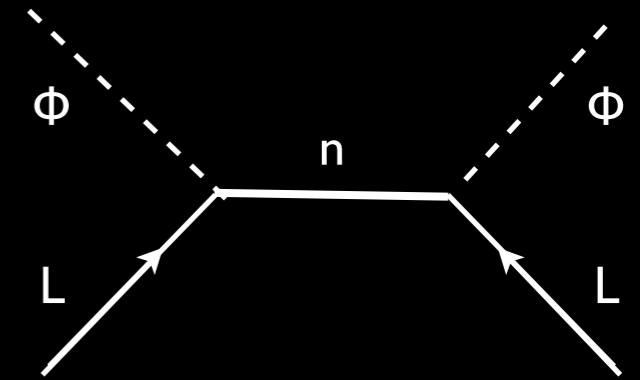

1310.8642

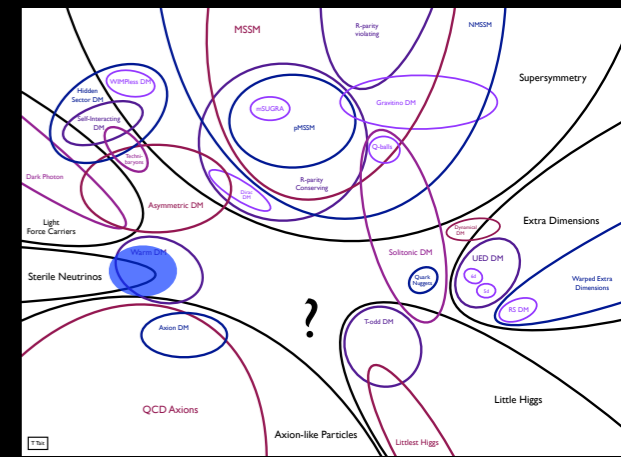

Sterile Neutrino Decay

- Though rare, sterile neutrinos can decay into ordinary neutrinos and a photon, resulting in (mono-energetic) keV energy photons.
- Constraints from the lack of observation of such a signal put limits in the plane of the mass versus the mixing angle.

Possible X-ray Signal
(mentioned by Tracy)
[Bulbul et al 2014]

(Extracted from
Abazajian 2014)

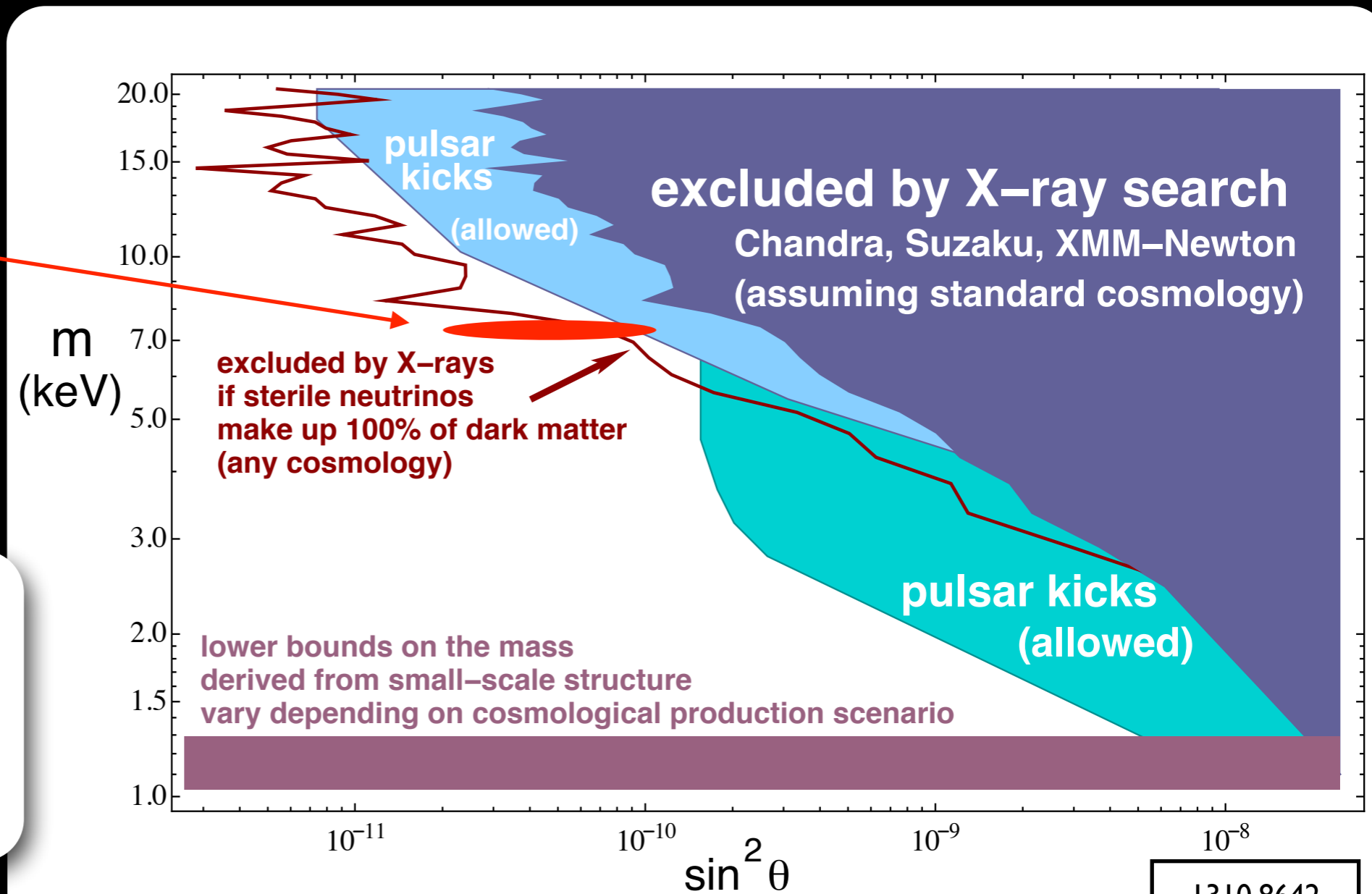
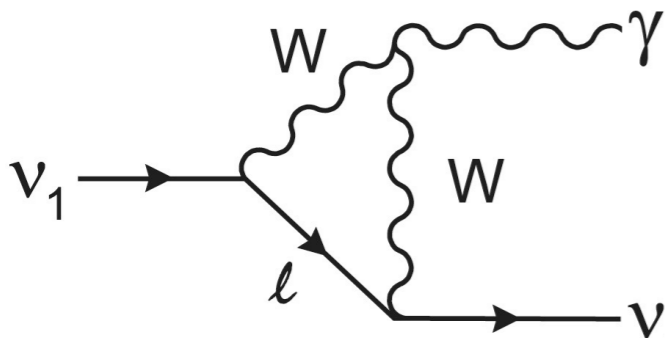

Designer Dark Matter

- As our searches for dark matter mature, we hope to eventually see a hint for a signal.
- There is no completely compelling evidence for an observation, but there are some tantalizing hints for things we don't understand. They might even be WIMPs!
- We can hope to eventually construct a theory of dark matter from observation.
- Even if the hints don't stand the test of time, they may inspire unconventional visions for how dark matter could work. They're still valuable to inspire new experiments and analyses.

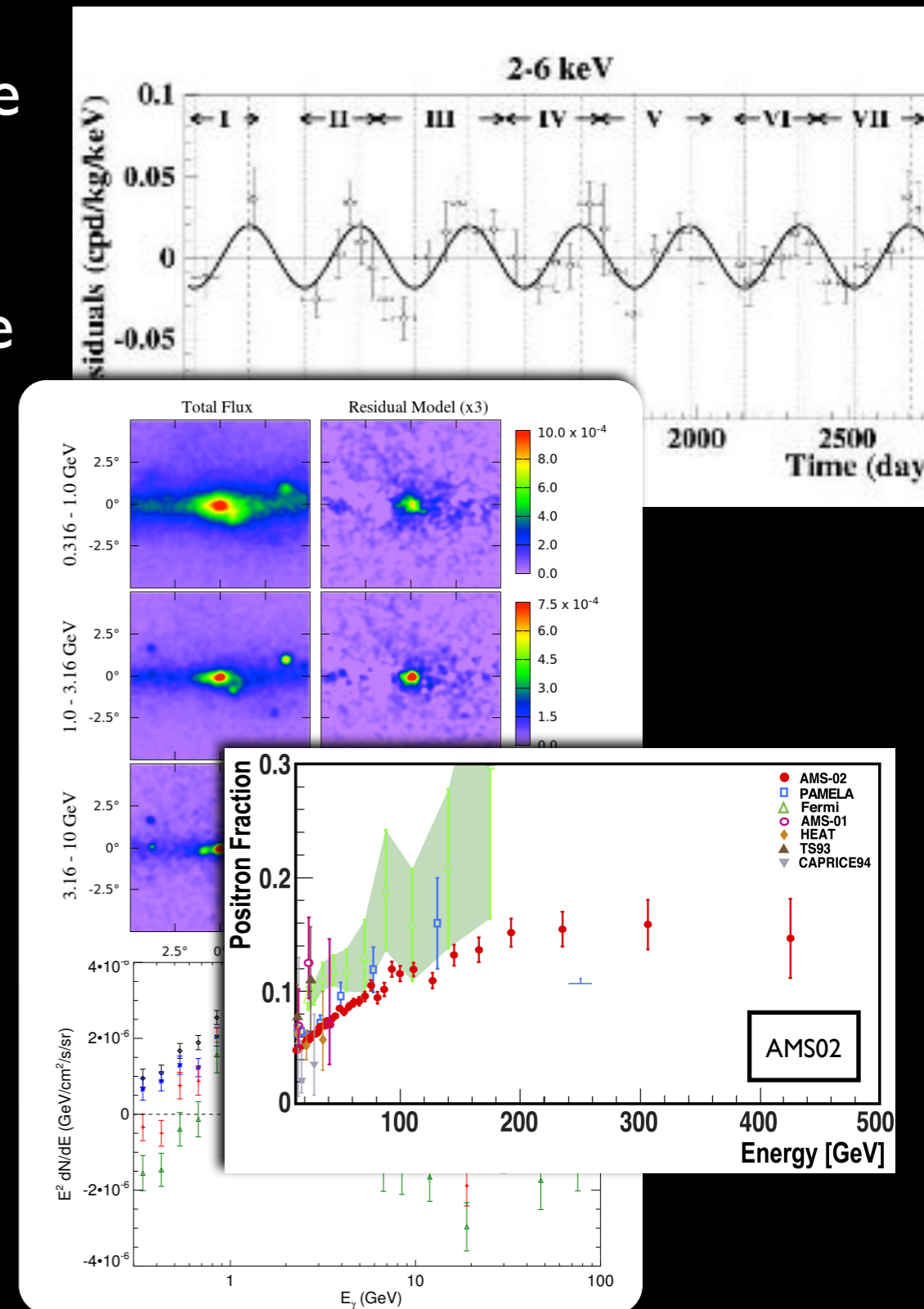

Light Mediators

- The PAMELA (and now Fermi and AMS02) positron excesses are an interesting signal that could be from dark matter annihilation/decay.
- A DM explanation runs into tension between the rate of annihilation required to produce a large enough signal compared with the relic density.
- A popular idea to reconcile the two is to introduce a light mediator (such as a dark photon) to invoke a Sommerfeld-like enhancement at small WIMP velocities.
- Summing up the effect of the mediator on the scattering can lead to a large enhancement factor compared to the leading order annihilation rate.

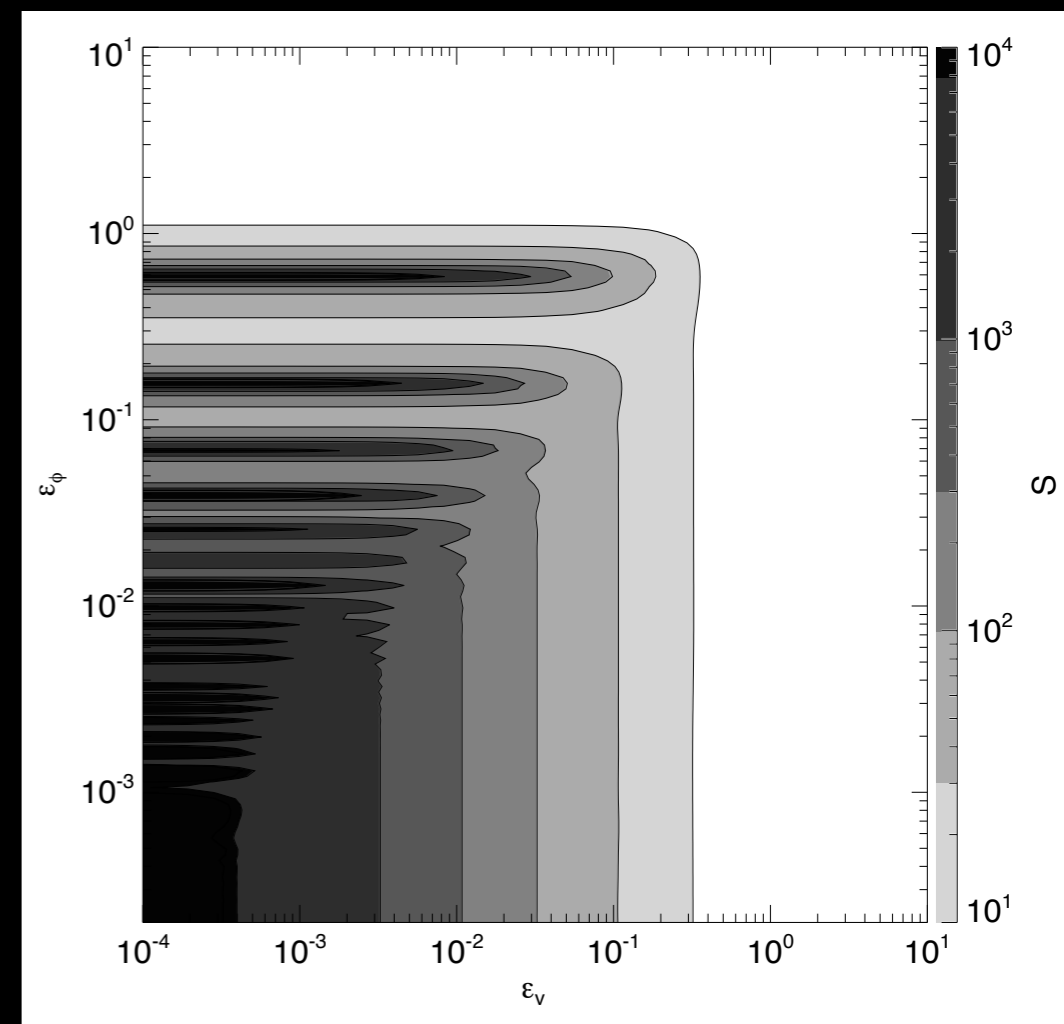

$$\epsilon_{\phi} \equiv \frac{m}{\alpha M} \qquad \epsilon_{\nu} \equiv \frac{\nu}{\alpha}$$

Cirelli, Kadastik, Raidal, Strumia 0809.2409
 Arkani-Hamed, Finkbeiner, Slatyer, Weiner 0810.0713

...

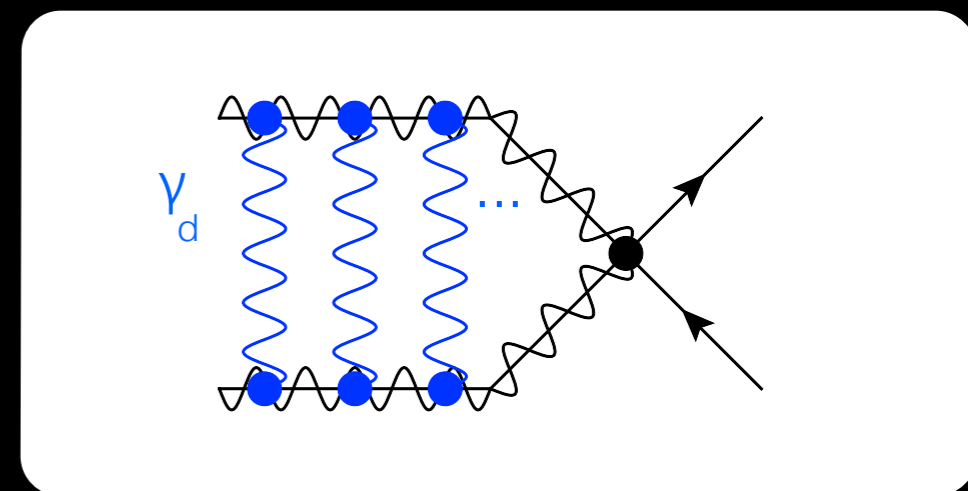

Self-Interacting DM?

- As Tracy explained yesterday, comparisons of observations with simulations for galaxy formation reveal tensions which could be ameliorated by positing dark matter which is strongly self-interacting.
- For example, dark matter with large enough self-interactions could retain the successes describing large scale structure, but show measurable differences at the smallest scales.
- There is some (controversial) evidence that this may help simulation better describe observation.
- Nonetheless, astronomy provides a unique perspective on properties that particle searches cannot probe.

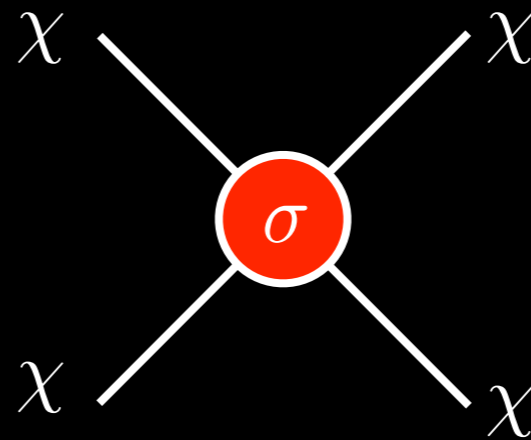

$$\sigma / m < 0.7 \text{ cm}^2 / \text{g}$$

(at a relative speed of ~ 3000 km/s)

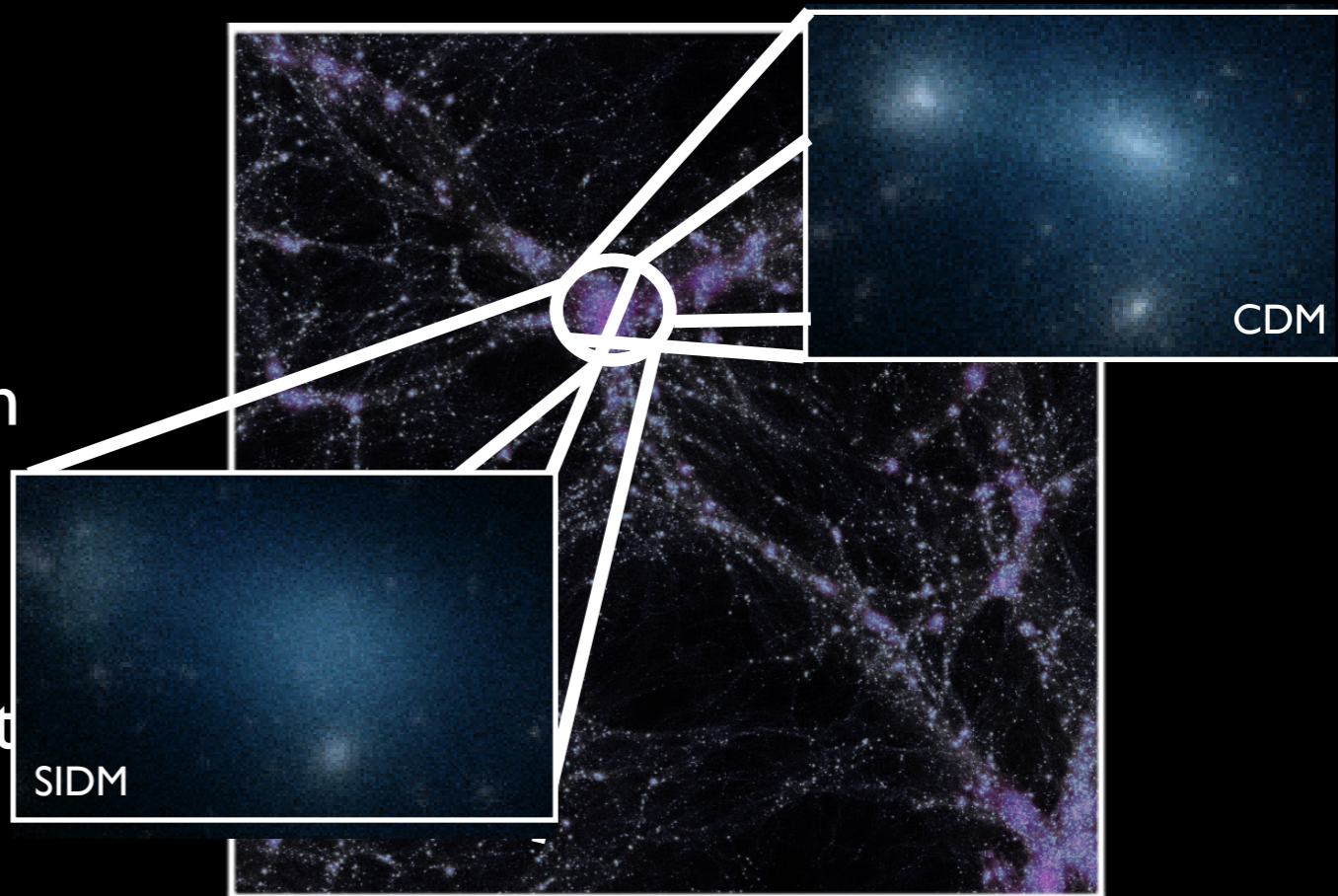

Example: A Dark SU(N)

Boddy, Feng, Kaplinghat,
Shadmi, TMPT 2014

- We can engineer large self interaction by considering a dark sector which is pure gauge theory hidden sector SU(N).
- If any matter charged under the hidden gauge group and the SM is extremely heavy, there is no relevant interaction between the dark sector and the SM.
- At high energies, the theory is described by weakly coupled dark gluons.
- At low energies, the dark gluons confine into massive dark glueballs.
- The theory is defined by the number of colors N and confinement scale Λ , which characterizes the mass of the lowest glueball state, and the splitting between the various glueballs.

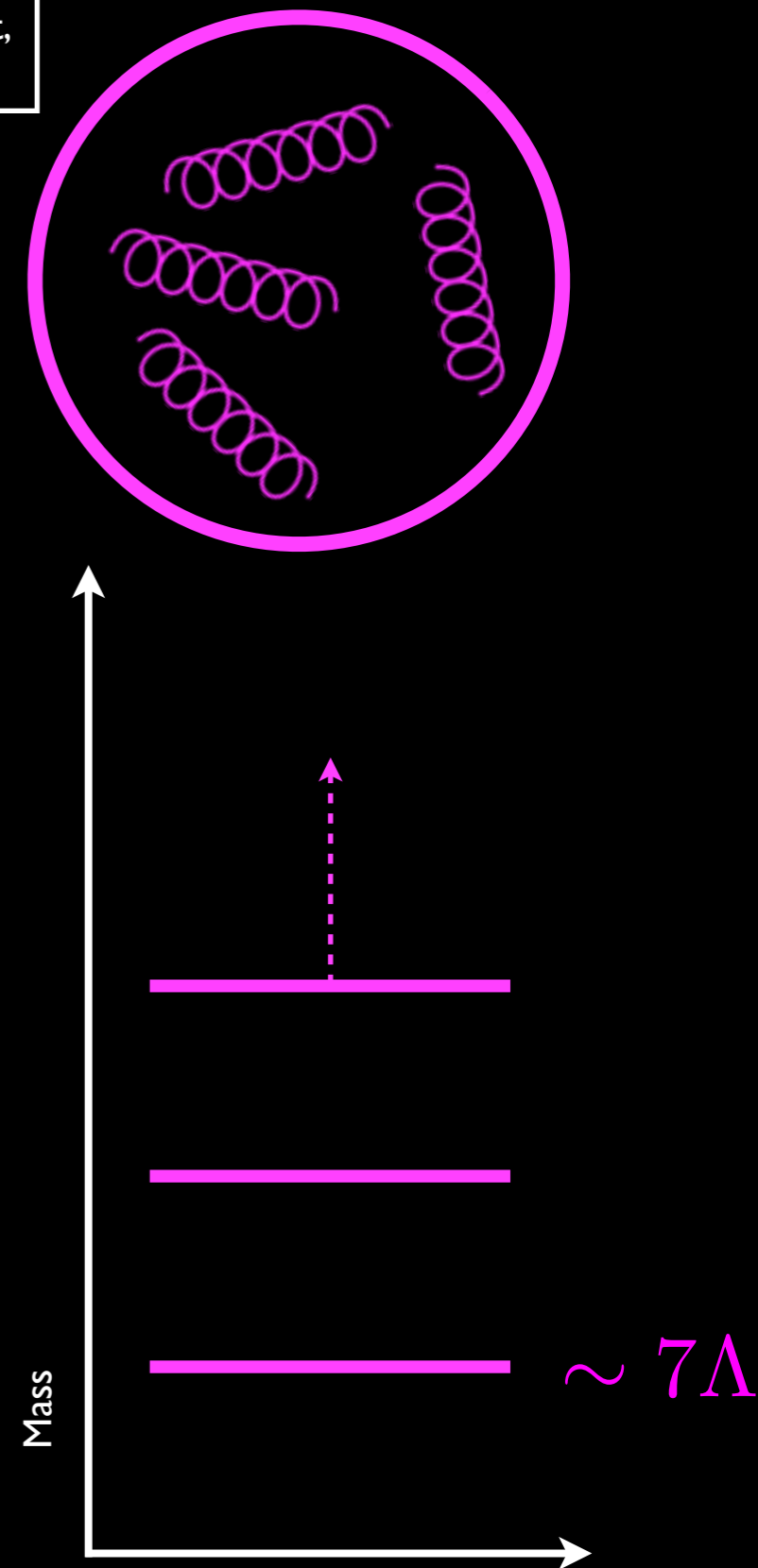

Glueball Interactions

- In this theory, nothing can be computed very reliably in perturbation theory.
- Lattice gauge theory may be able to help.
- Nonetheless, the self-interactions of the glueballs will be roughly given by the geometric cross section for strongly coupled objects of size $\sim 1 / \Lambda$.

$$\sigma (\text{gb gb} \rightarrow \text{gb gb}) \sim \frac{4\pi}{\Lambda^2 N^2}$$

- Since the single parameter Λ controls both the mass and the cross section (for small N), arranging for an interesting value of σ/m essentially fixes $\Lambda \sim 500 \text{ MeV}$.

Amusingly close to $\Lambda_{\text{QCD}} \dots$

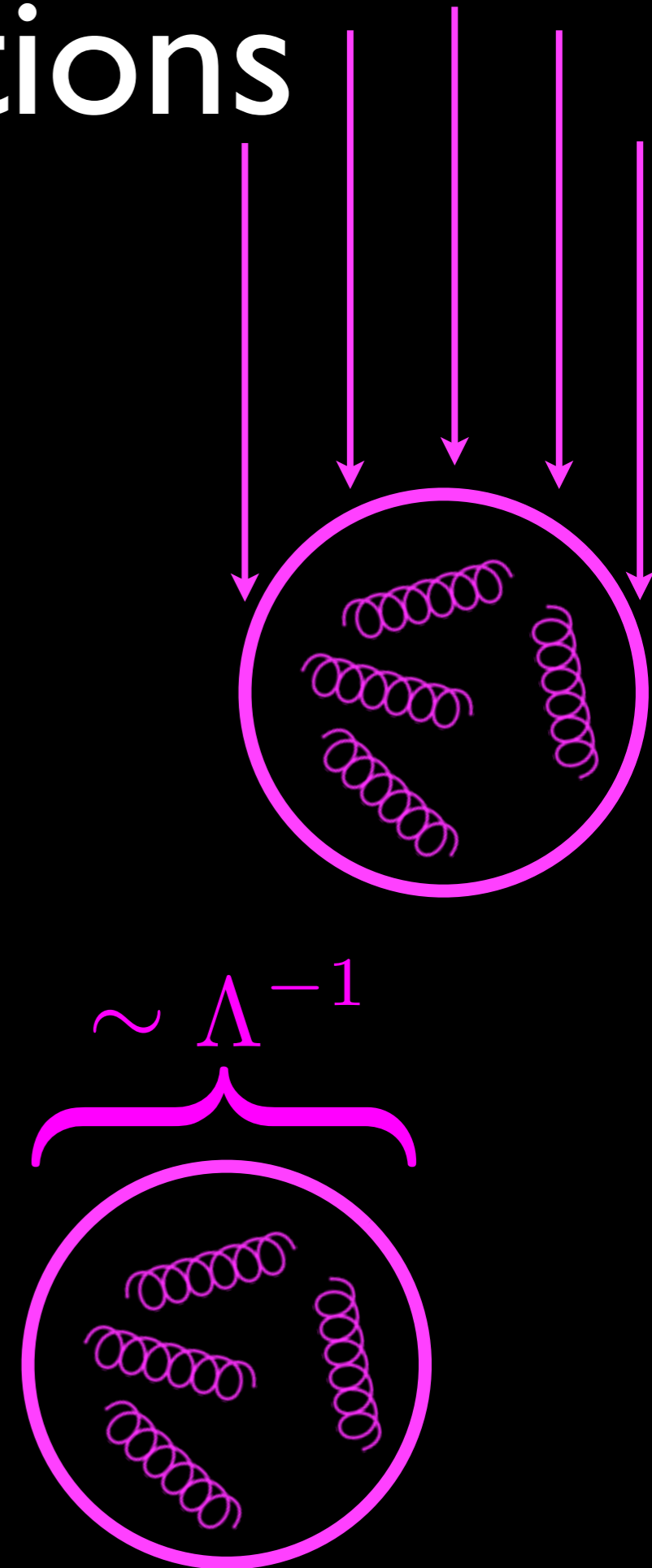

Glueball Parameter Space

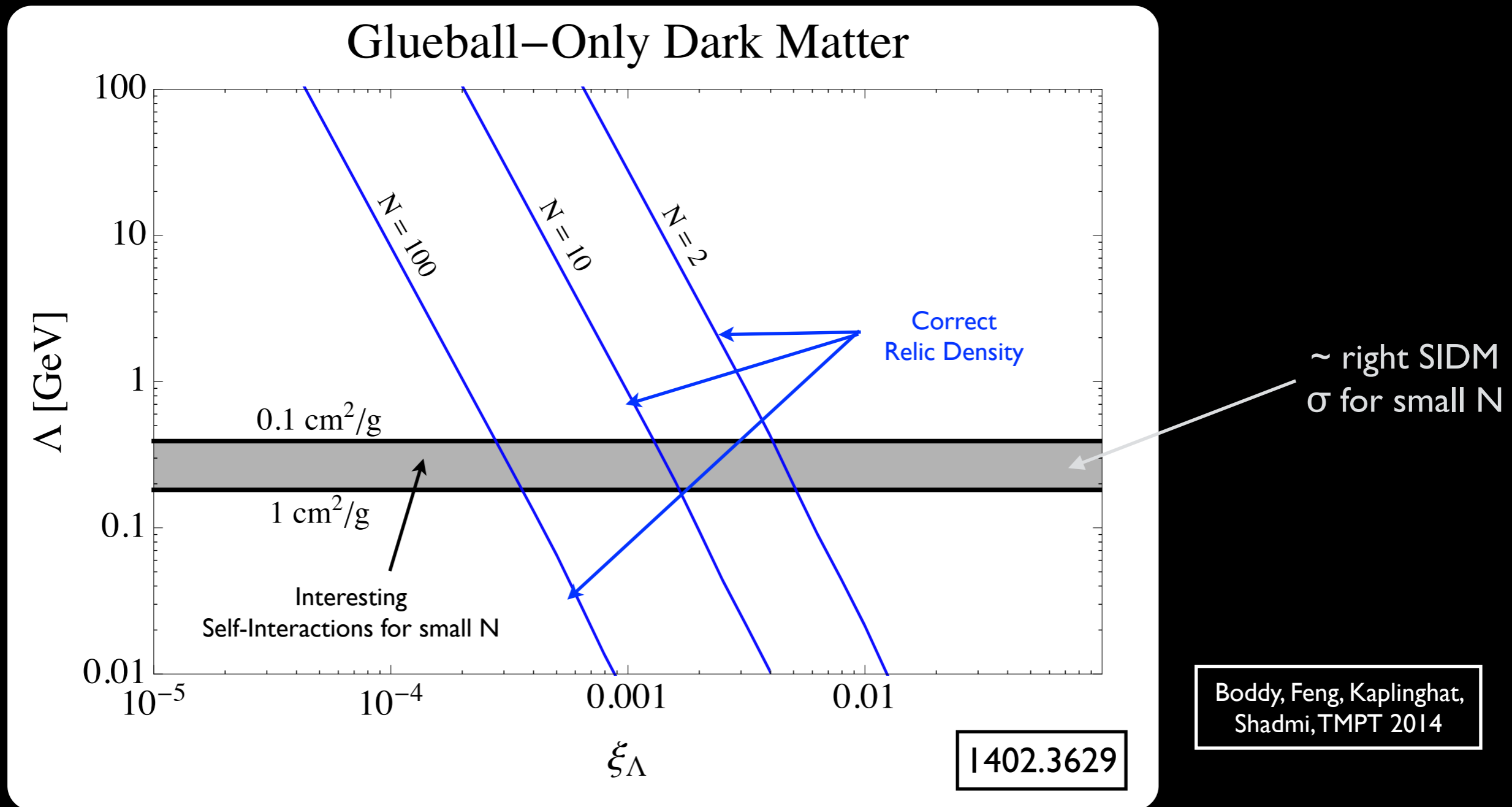

- The relic density of the glueballs depends on the temperature of the hidden sector relative to the SM ($\xi = T_h / T_{\text{SM}}$). An interesting parameter space has \sim observable self-interactions and the correct relic density.

Sketches of Theories

- Another area of wide activity is to try to capture simple features of models of WIMPs that are not inspired by a particular paradigm.
- While perhaps not able to describe the whole story, these simplified models could potentially still capture the most important features of a theory of dark matter.
- We'll see that they are useful to help us piece together what information we get from our different kind of searches, to understand how they complement one another.
- In the limit where any particle mediating interaction between the SM and the DM is extremely heavy, all models flow to a universal set of effective field theories.

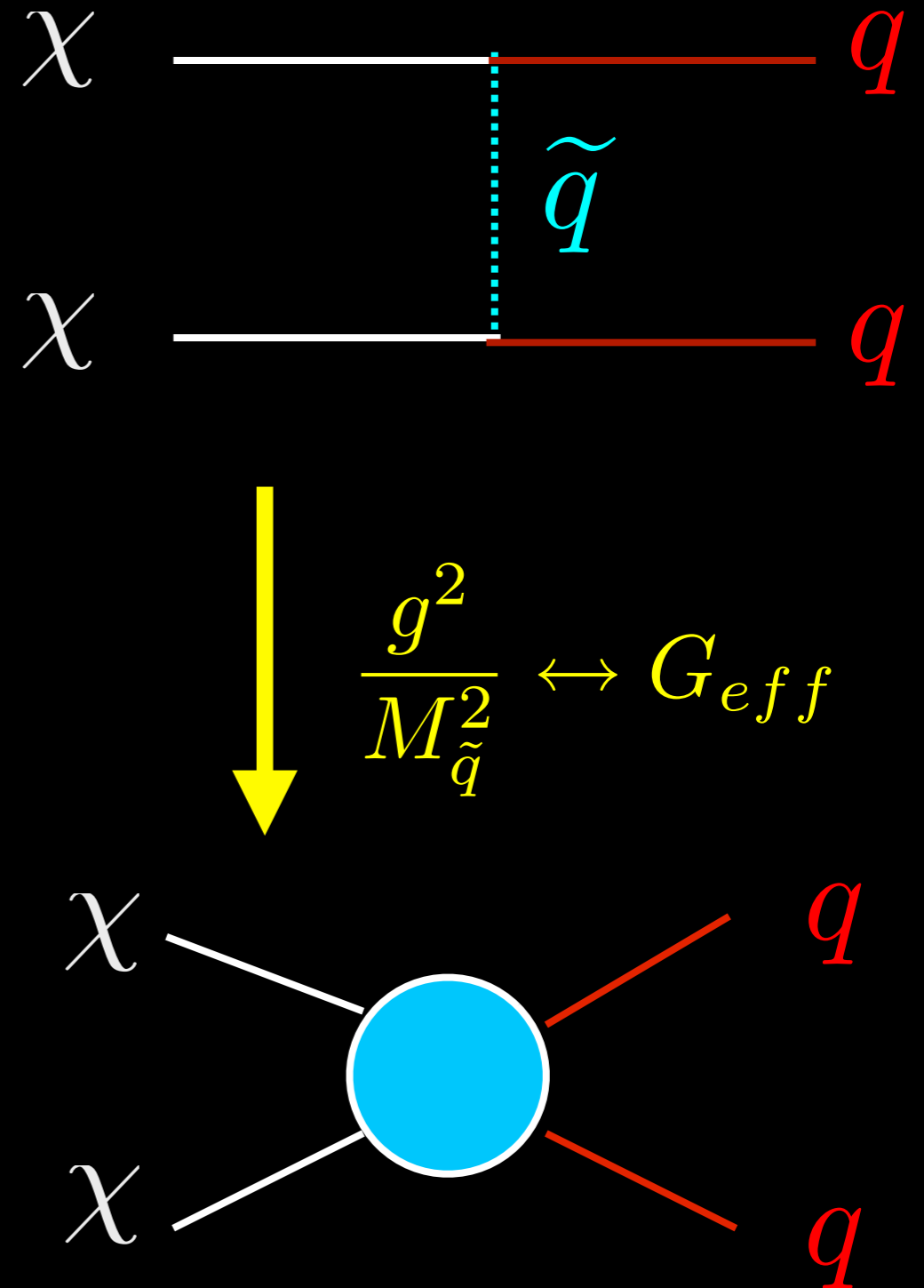

Example: Majorana WIMP

Goodman, Ibe, Rajaraman, Shepherd, TMPT, Yu 1005.1286 & PLB

- As an example, we can write down the operators of interest for a Majorana WIMP.
- There are 10 leading operators consistent with Lorentz and gauge invariance that describe WIMPs coupling to quarks or gluons.
- Each operator has a (separate) coefficient M_* which parametrizes its strength.
- In principle, a realistic UV theory will turn on some combination of them, with related coefficients.

Name	Type	G_χ	Γ^χ	Γ^q
M1	qq	$m_q/2M_*^3$	1	1
M2	qq	$im_q/2M_*^3$	γ_5	1
M3	qq	$im_q/2M_*^3$	1	γ_5
M4	qq	$m_q/2M_*^3$	γ_5	γ_5
M5	qq	$1/2M_*^2$	$\gamma_5 \gamma_\mu$	γ^μ
M6	qq	$1/2M_*^2$	$\gamma_5 \gamma_\mu$	$\gamma_5 \gamma^\mu$
M7	GG	$\alpha_s/8M_*^3$	1	-
M8	GG	$i\alpha_s/8M_*^3$	γ_5	-
M9	$G\tilde{G}$	$\alpha_s/8M_*^3$	1	-
M10	$G\tilde{G}$	$i\alpha_s/8M_*^3$	γ_5	-

$$G_\chi [\bar{\chi} \Gamma^\chi \chi] G^2$$

$$\sum_q G_\chi [\bar{q} \Gamma^q q] [\bar{\chi} \Gamma^\chi \chi]$$

Other operators may be rewritten in this form by using Fierz transformations.

Example: Majorana WIMP

Goodman, Ibe, Rajaraman, Shepherd, TMPT, Yu 1005.1286 & PLB

- The various types of interactions are accessible to different kinds of experiments.

- Spin-independent elastic scattering

- Spin-dependent elastic scattering

- Annihilation in the galactic halo

- Collider Production

Name	Type	G_χ	Γ^χ	Γ^q
M1	qq	$m_q/2M_*^3$	1	1
M2	qq	$im_q/2M_*^3$	γ_5	1
M3	qq	$im_q/2M_*^3$	1	γ_5
M4	qq	$m_q/2M_*^3$	γ_5	γ_5
M5	qq	$1/2M_*^2$	$\gamma_5 \gamma_\mu$	γ^μ
M6	qq	$1/2M_*^2$	$\gamma_5 \gamma_\mu$	$\gamma_5 \gamma^\mu$
M7	GG	$\alpha_s/8M_*^3$	1	-
M8	GG	$i\alpha_s/8M_*^3$	γ_5	-
M9	$G\tilde{G}$	$\alpha_s/8M_*^3$	1	-
M10	$G\tilde{G}$	$i\alpha_s/8M_*^3$	γ_5	-

$$G_\chi [\bar{\chi} \Gamma^\chi \chi] G^2$$

$$\sum_q G_\chi [\bar{q} \Gamma^q q] [\bar{\chi} \Gamma^\chi \chi]$$

Other operators may be rewritten in this form by using Fierz transformations.

Annihilation

- We can map each interaction into a prediction for WIMPs annihilating.
- This allows us to consider bounds from indirect detection, and with assumptions, maps onto a thermal relic density.
- We can use this simple sketch of a theory of dark matter to translate the results from direct and collider searches into the same parameter space.
- Colliders continue to do better for lighter WIMPs whereas direct detection is more sensitive to heavy WIMPs.

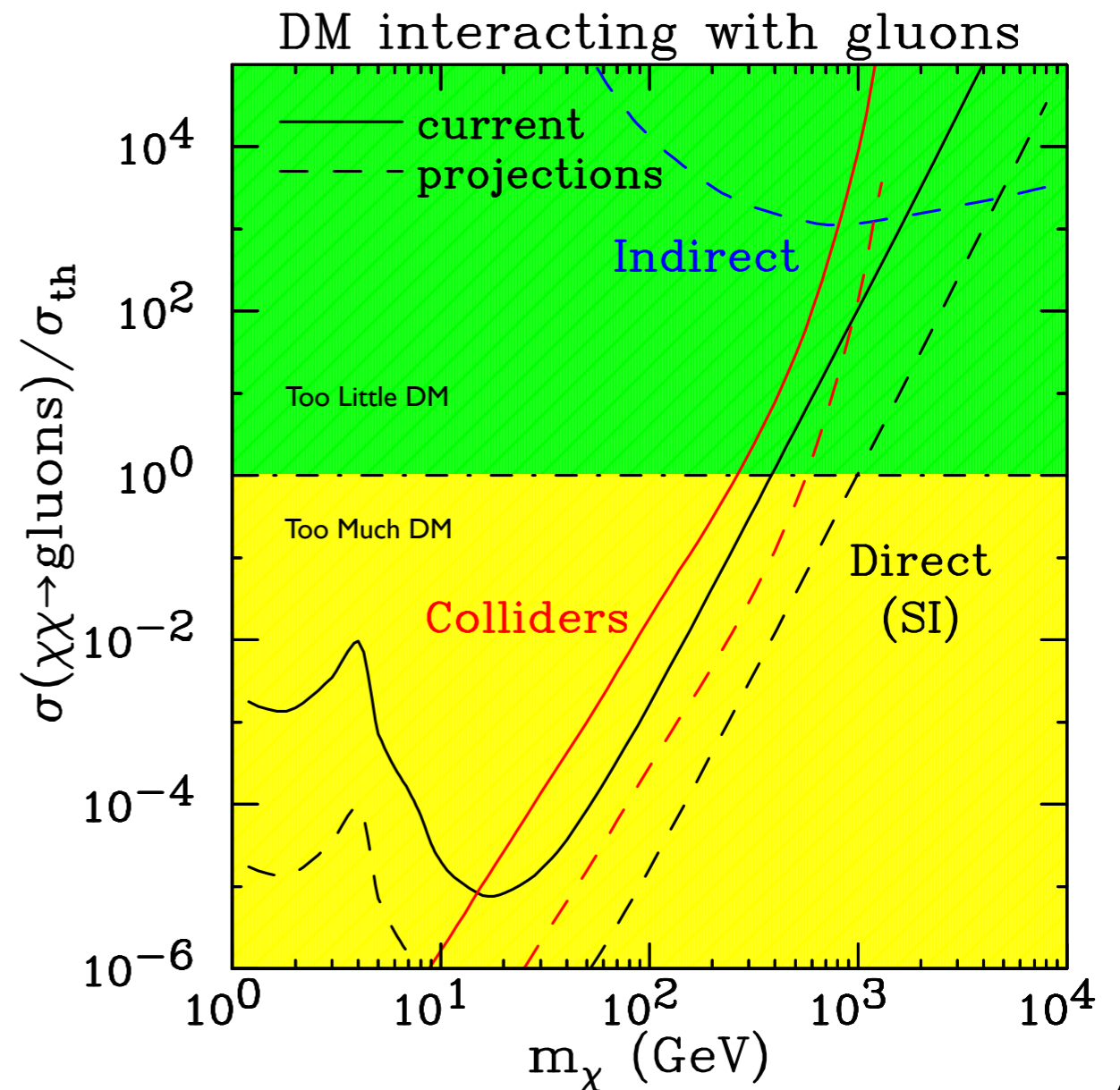
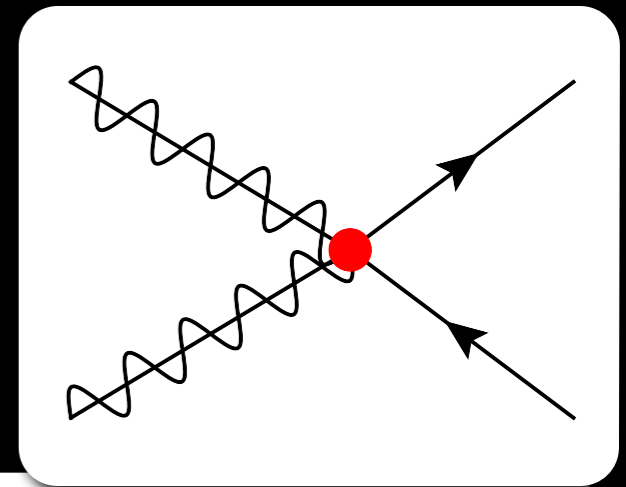

Quarks & Leptons

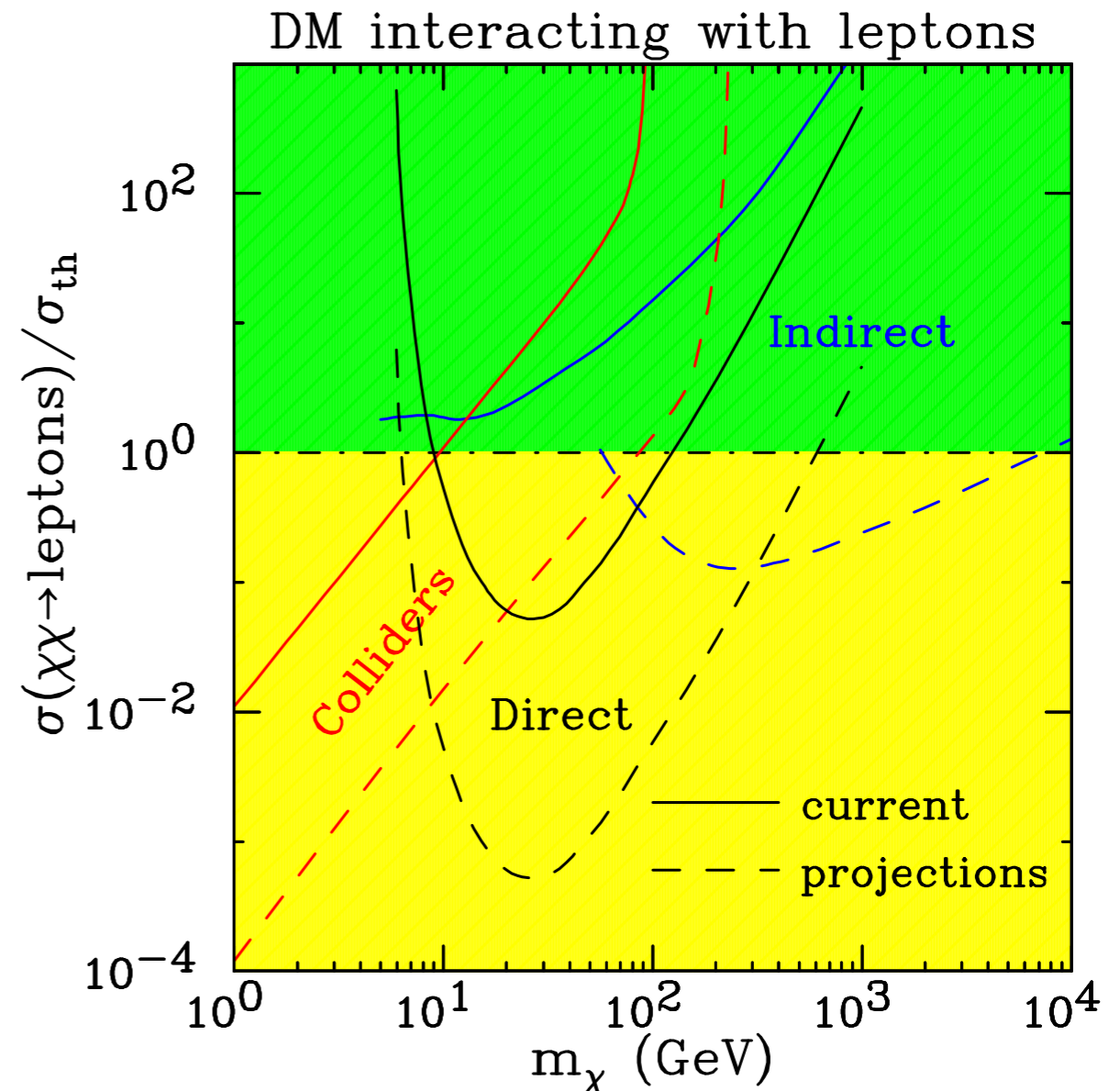
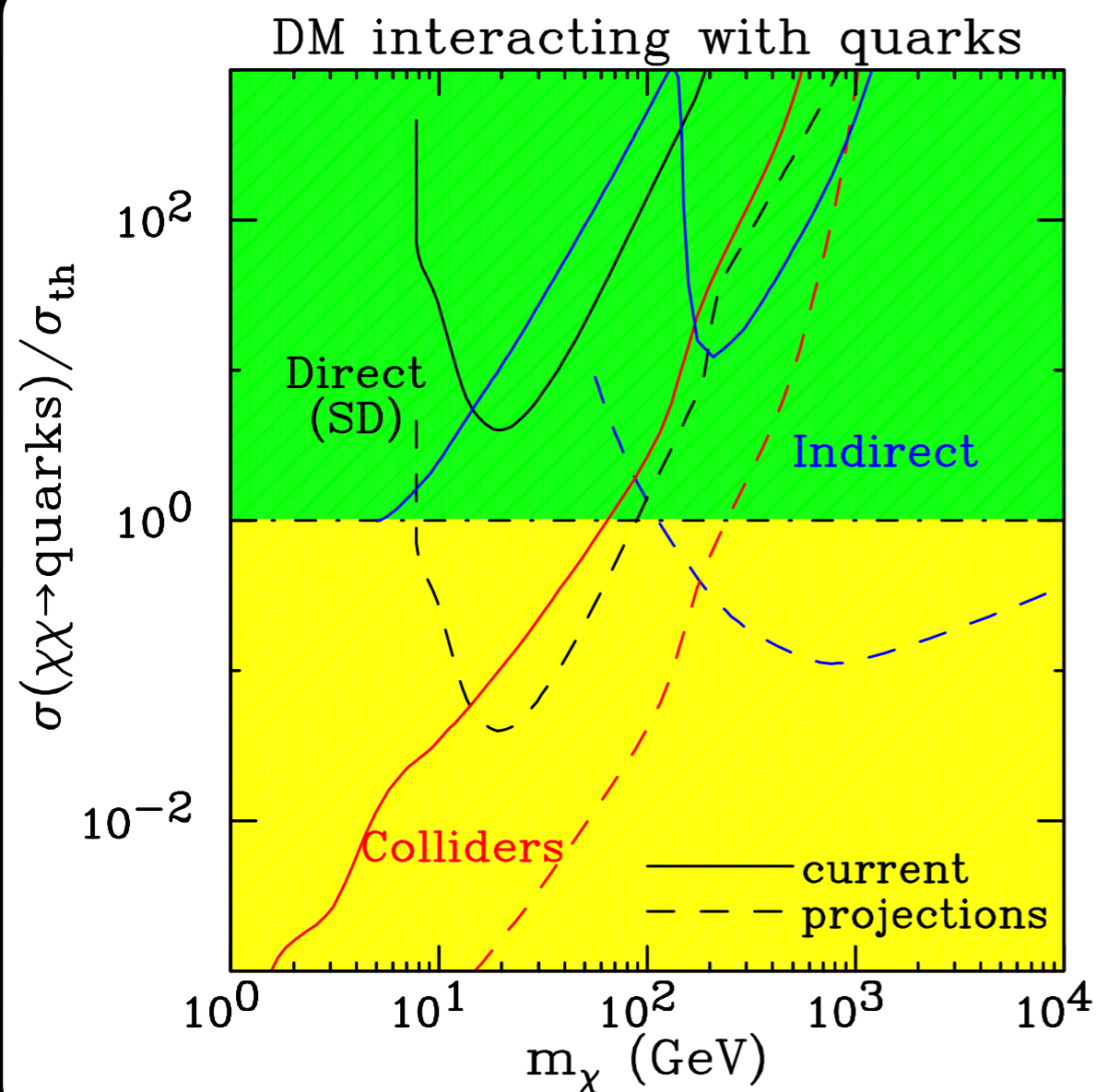

- Within this theory framework, there is a lot of complementarity in coverage of the parameter space.
- Covering the space is not enough. If we see conflicting information from two types of searches, it really means that we are seeing a break-down of our theoretical assumptions, which in this case means more light particles.

Simplified Model

- Moving toward a more complete theory, we can also consider a model containing the dark matter as well as the most important particle mediating its interaction with the Standard Model.
- For example, if we are interesting in dark matter interacting with quarks, we can sketch a theory containing a colored scalar particle which mediates the interaction.
- This theory looks kind of like a little part of a SUSY model, but has more freedom in terms of choosing couplings, masses, etc.
- There are basically three parameters to this model: the mass of the dark matter, the mass of the mediator, and the coupling strength with quarks.

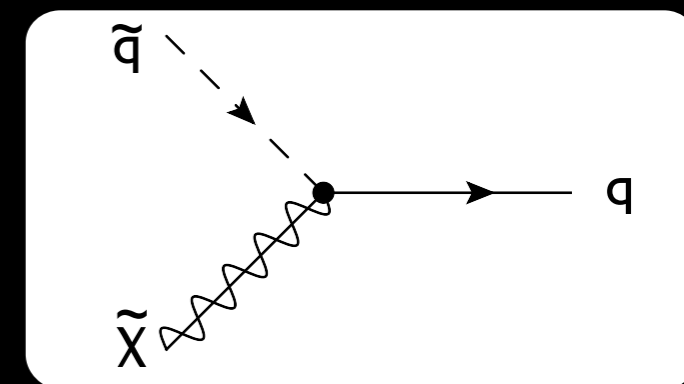
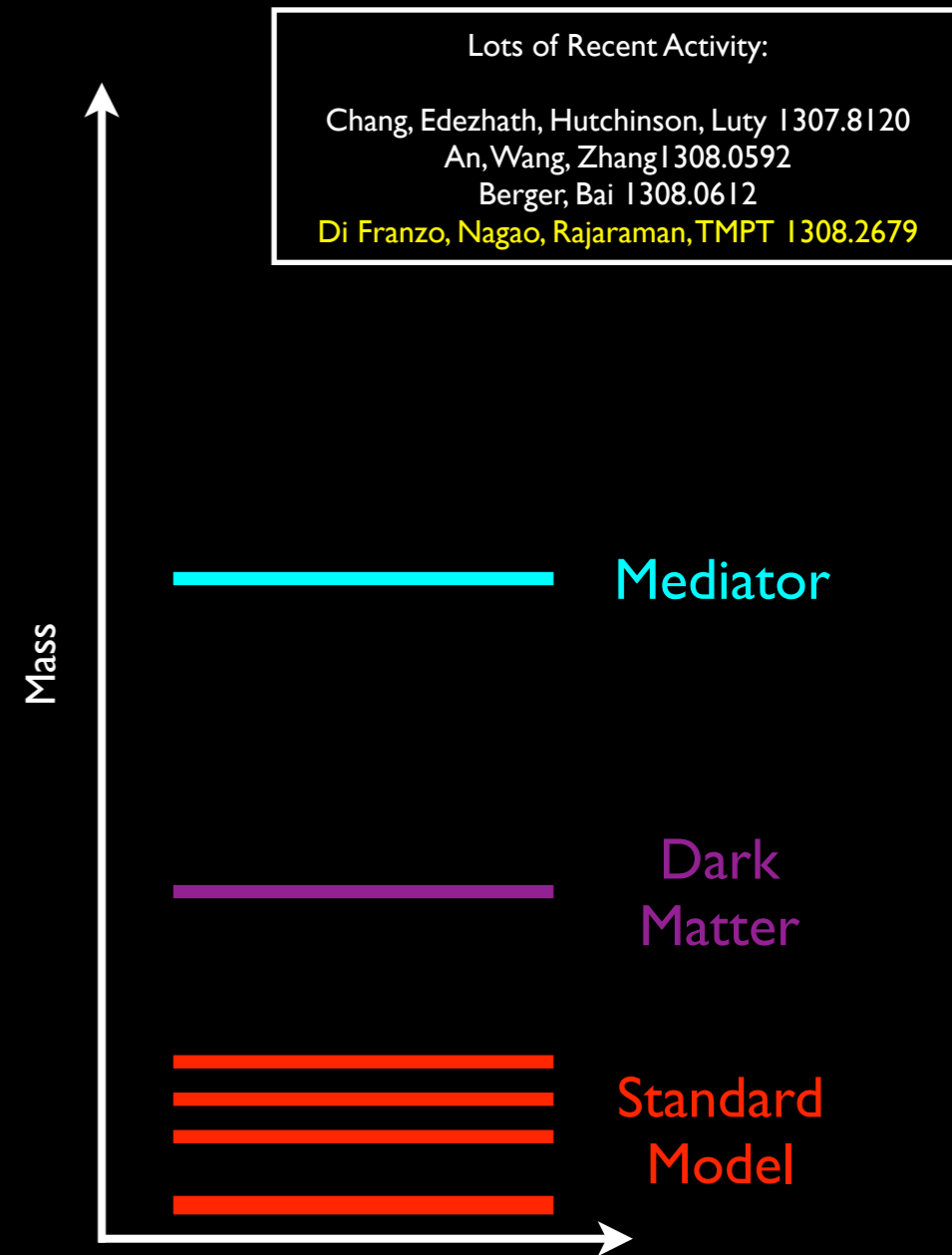

\tilde{u}_R Model

- For example, we can look at a model where a Dirac DM particle couples to right-handed up-type quarks.
- At colliders, the fact that the mediator is colored implies we can produce it at the LHC using the strong nuclear force (QCD; mostly from initial gluons) or through the interaction with quarks.
- Once produced, the mediator will decay into an ordinary quark and a dark matter particle.

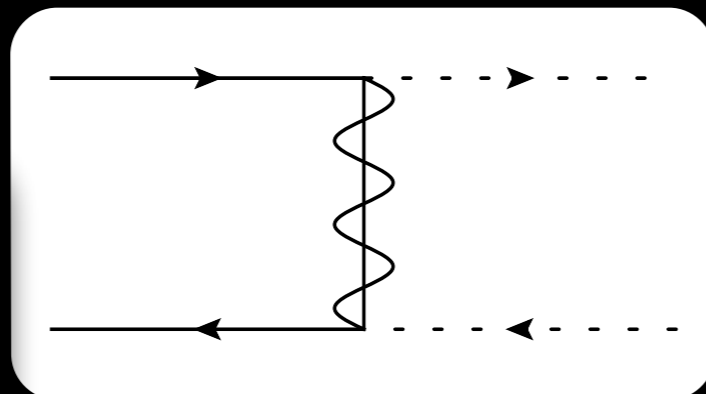
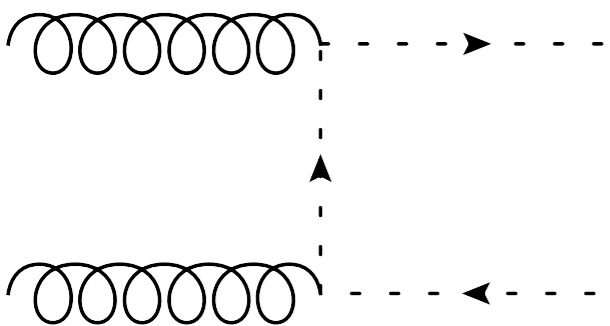

Weak bounds in the mass-degenerate region.

DiFranzo, Nagao, Rajaraman, TMPT
arXiv:1308.2679

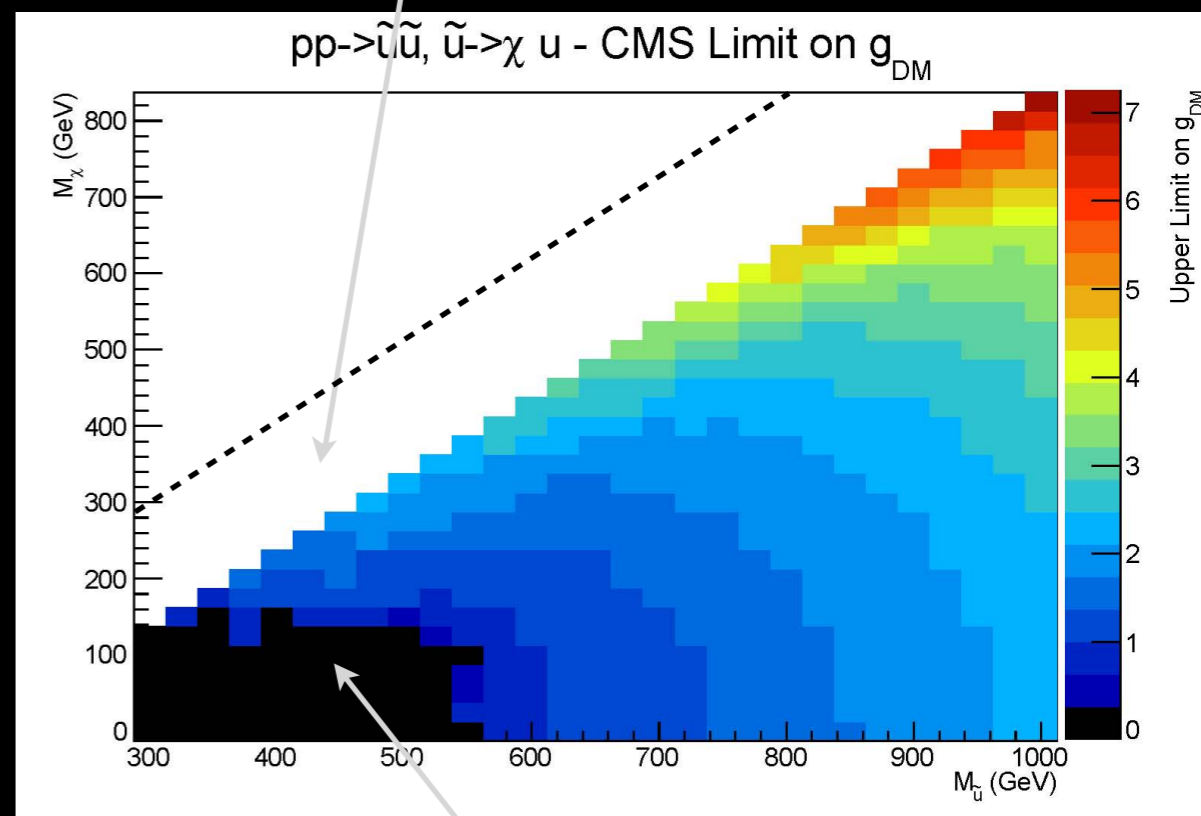

QCD production saturates the CMS limits, resulting in no allowed value of g .

\tilde{u}_R Model

- A Dirac WIMP also has spin-independent scattering with nucleons. For most of the parameter space, there are bounds from the Xenon-100 experiment. (And recently LUX has improved these limits by about a factor of two...).
- Elastic scattering does not rule out any parameter space, but it does impose stricter constraints on the allowed size of the coupling in the regions the LHC left as allowed.

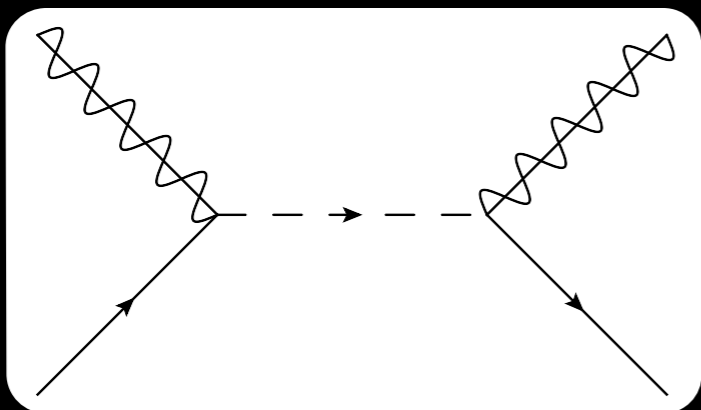

DiFranzo, Nagao, Rajaraman, TMPT
arXiv:1308.2679

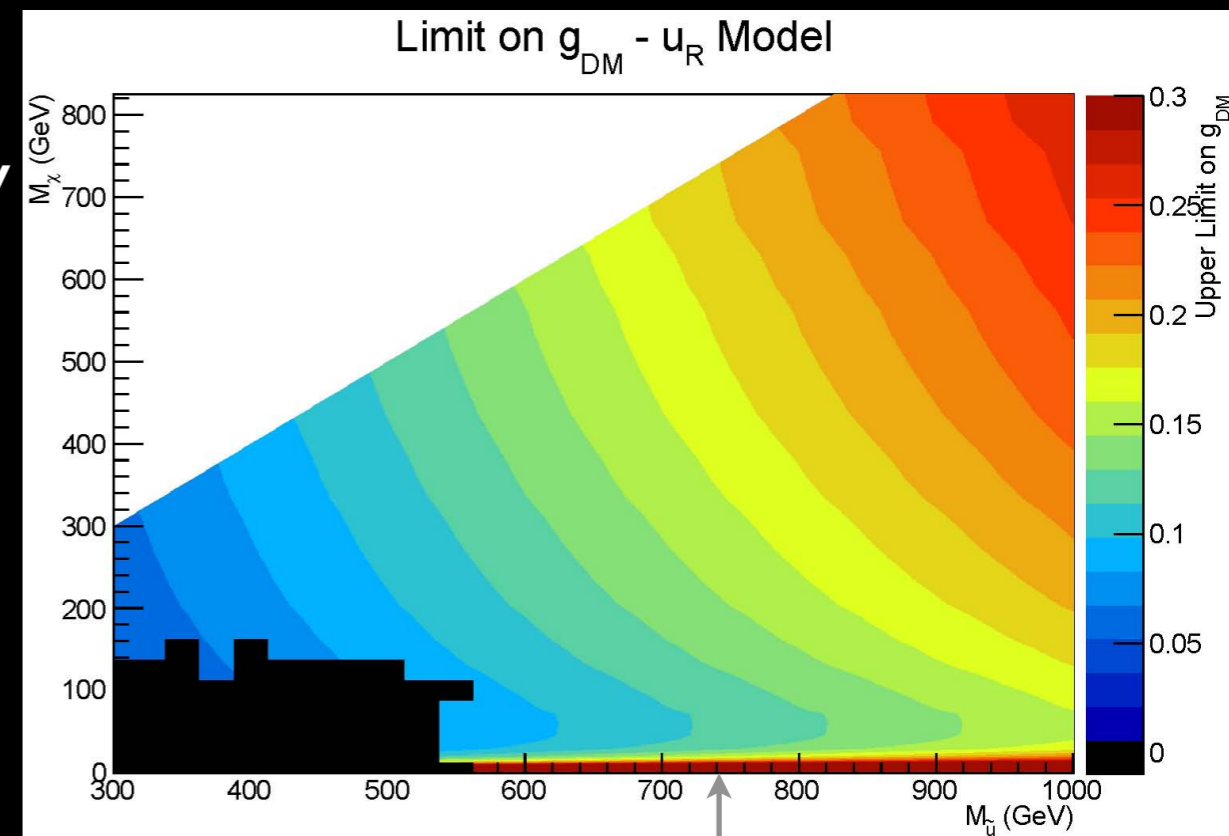

Traditional direct detection searches peter out for masses below about 10 GeV.

Majorana versus Dirac

DiFranzo, Nagao, Rajaraman, TMPT
arXiv:1308.2679

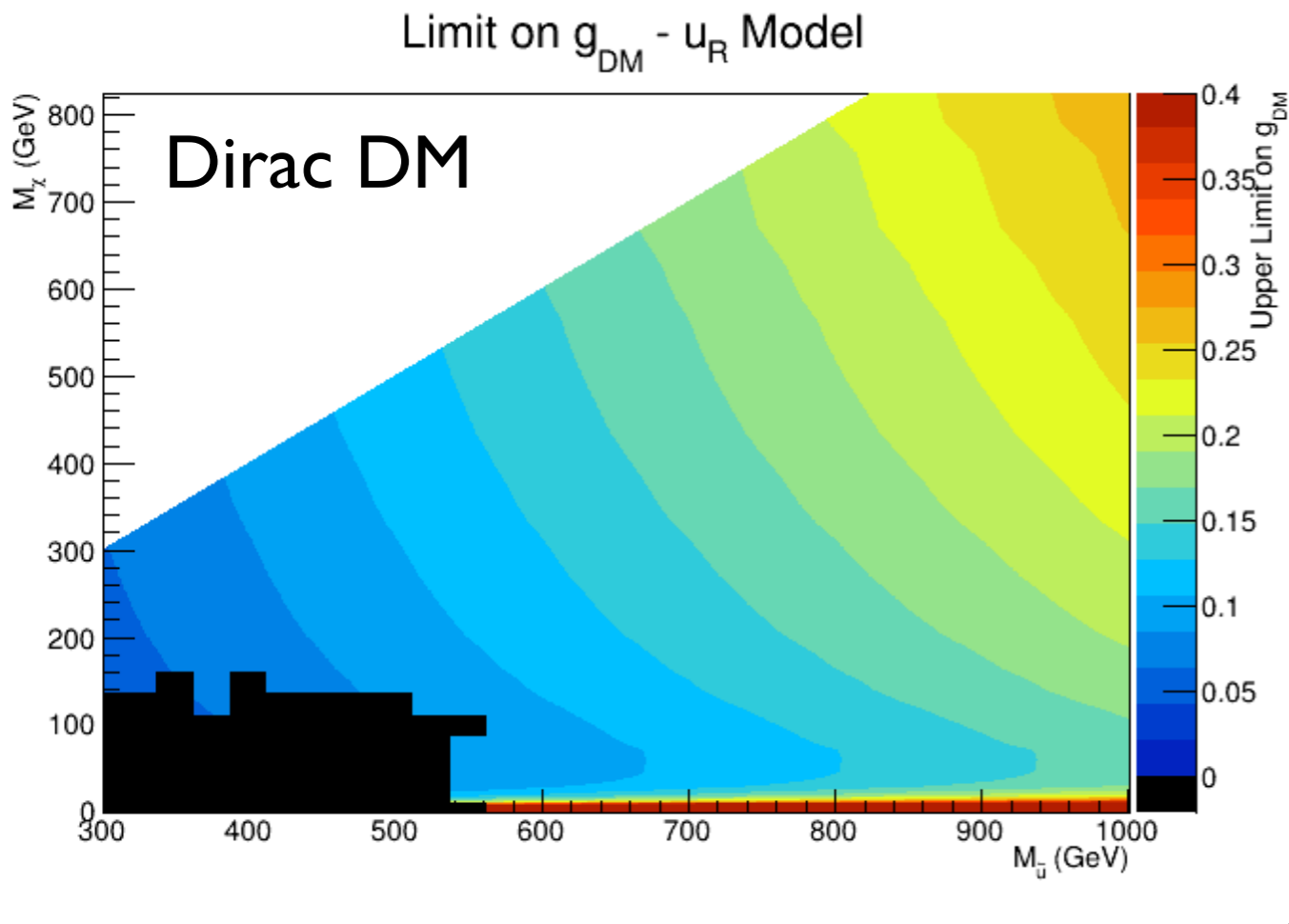

Collider bounds tend to dominate for Majorana DM.

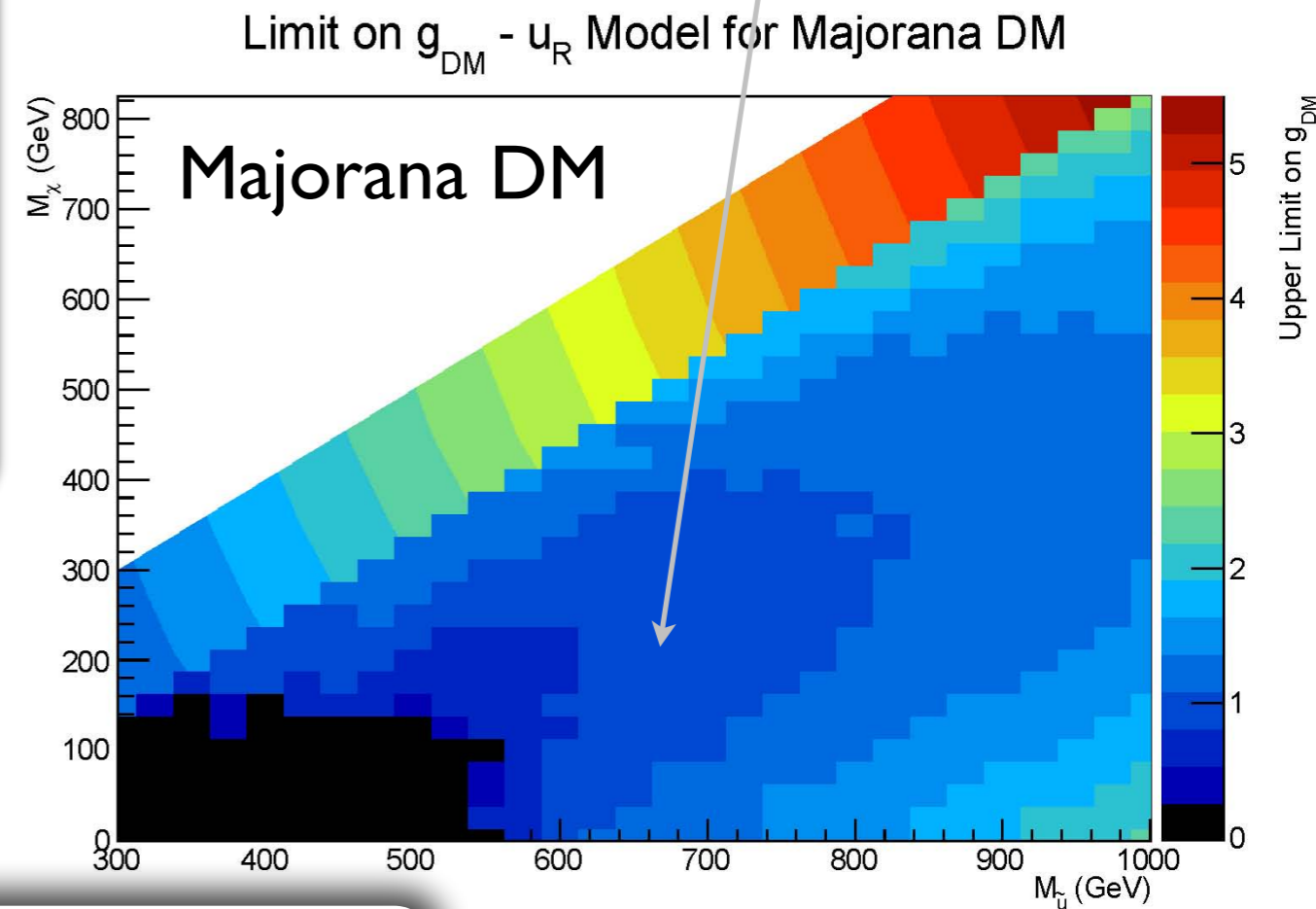

There are interesting differences that arise even from very simple changes, like considering a Majorana compared to a Dirac DM particle.

Majorana WIMPs have no tree-level spin-independent scattering in this model.

At colliders, t-channel exchange of a Majorana WIMP can produce two mediators, leading to a PDF-friendly qq initial state.

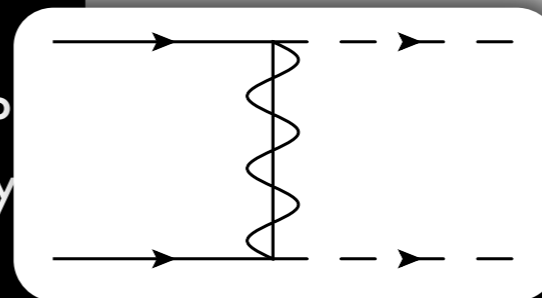

\tilde{u}_R Model: Forecasts

- Similarly, we can forecast for the annihilation cross section.
- The Fermi LAT does not put very interesting constraints at the moment, but it is very close to doing so, and limits from dwarf satellite galaxies are likely to be relevant in the near future for Majorana Dark Matter.
- We can also ask where in parameter space this simple module would lead to a thermal relic with the correct relic density.

DiFranzo, Nagao, Rajaraman, TMPT
arXiv:1308.2679

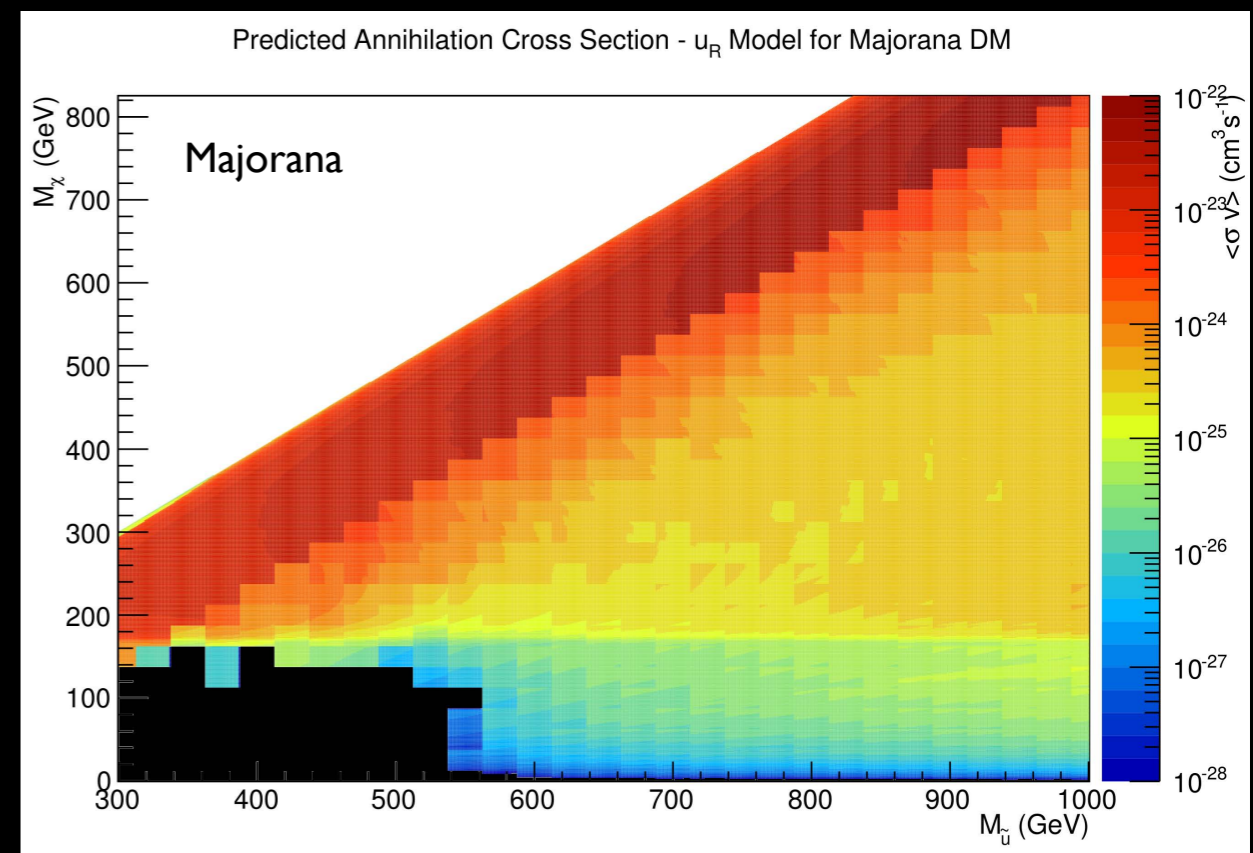
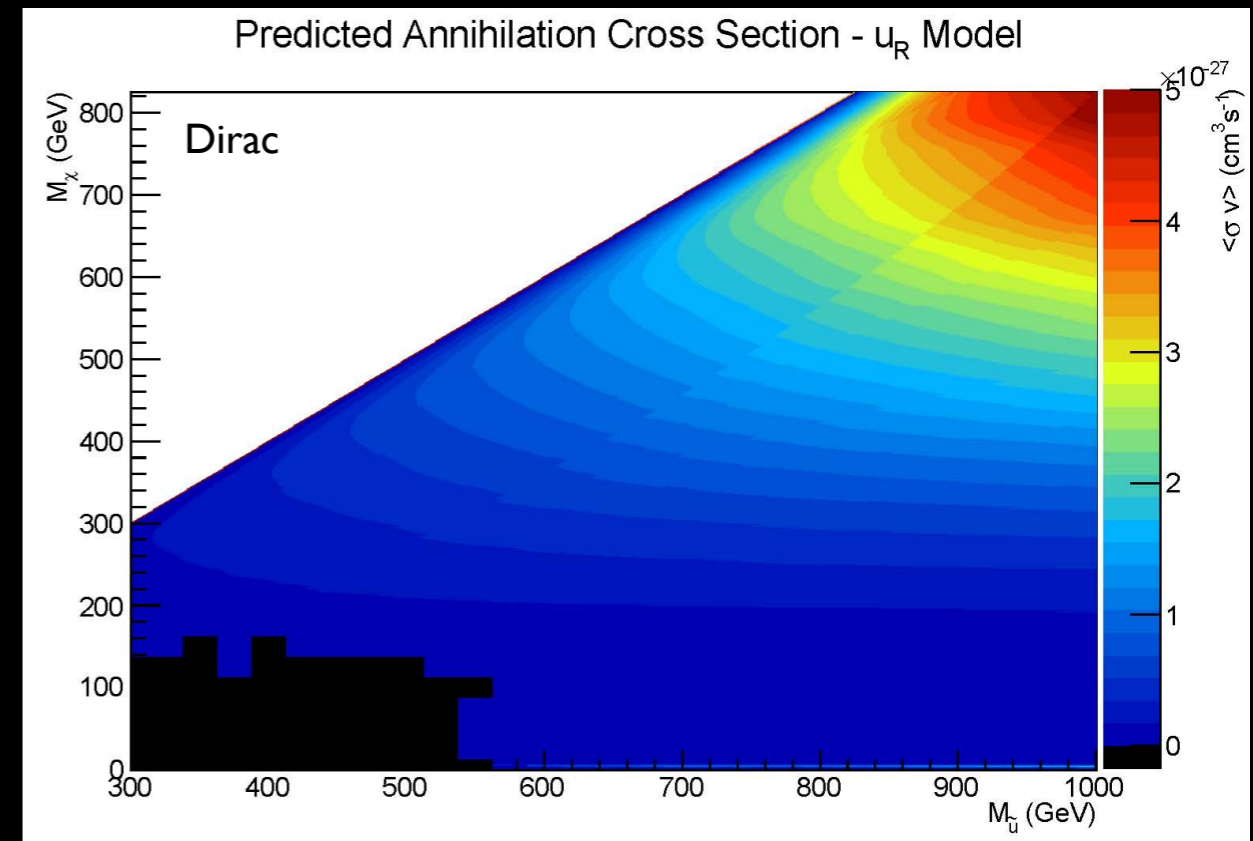

\tilde{u}_R Model: Forecasts

- Similarly, we can forecast for the annihilation cross section.
- The Fermi LAT does not put very interesting constraints at the moment, but it is very close to doing so, and limits from dwarf satellite galaxies are likely to be relevant in the near future for Majorana DM.
- We can also ask where in parameter space this simple module would lead to a thermal relic with the correct relic density ($\sigma v \sim 10^{-26} \text{ cm}^3/\text{s}$).

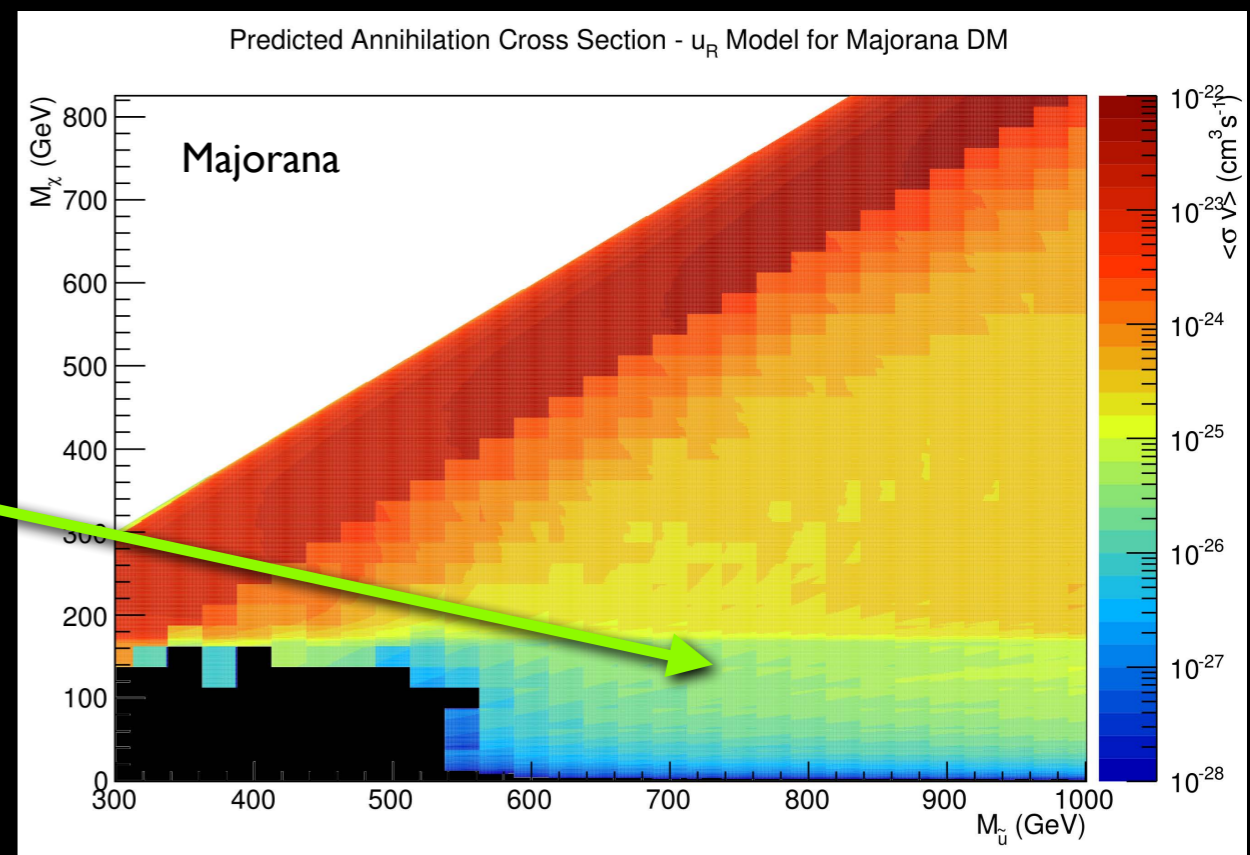
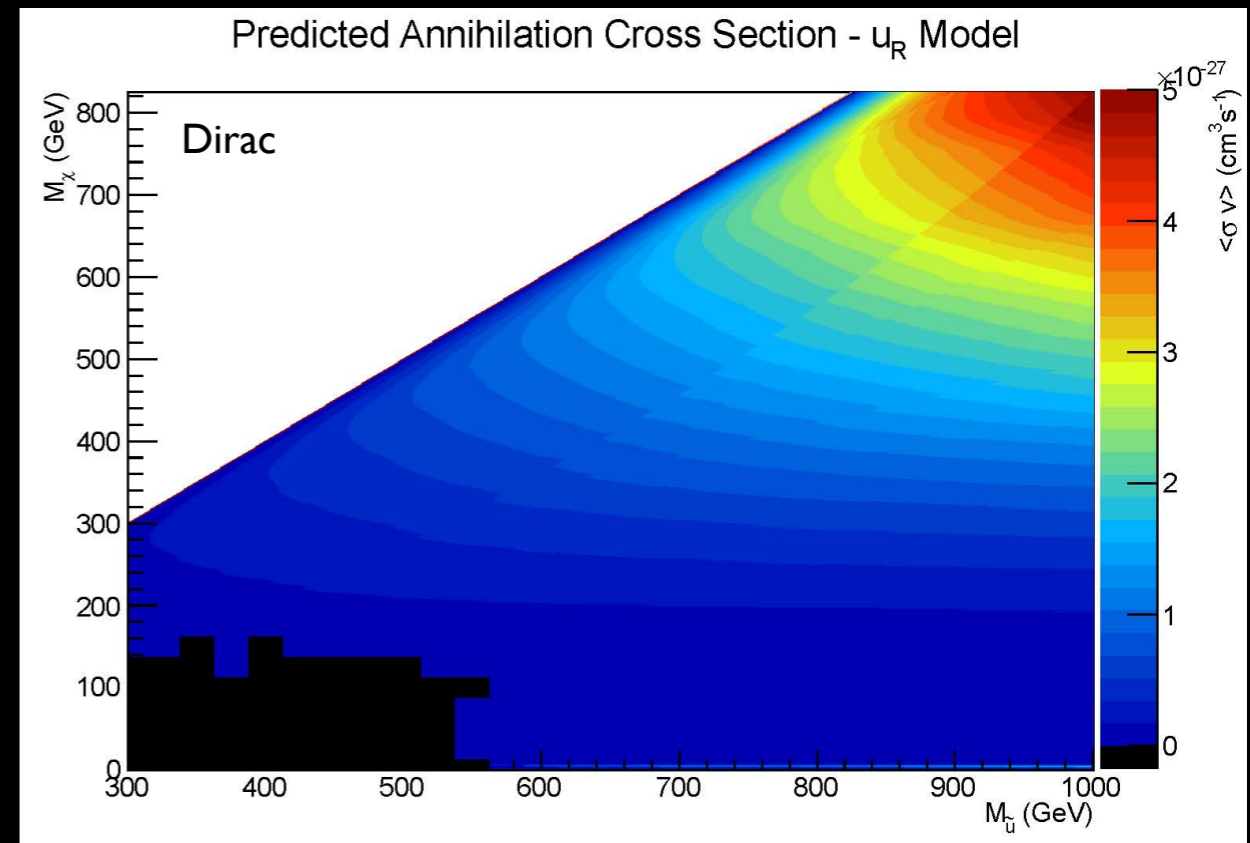
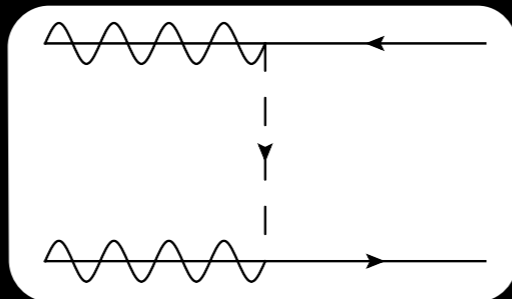

Recap

- In lecture 2, we saw more examples of theories of dark matter.
 - The UED WIMP serves to illustrate the case in which dark matter is a boson, either a vector (5d) or a scalar (6d).
 - Little Higgs theories with T-parity also have a vector WIMP, but one which prefers to couple to massive particles.
 - Both show big differences compared to a SUSY Majorana WIMP!
- Super-WIMPs are harder to search for, and may be a hint of a nonstandard thermal history.
- Designer dark matter tries to fit the dark matter to the observations, rather than the other way around.
 - Eventually, we can hope to assemble a designer theory of dark matter into a more fundamental theory with connections to deep questions.